

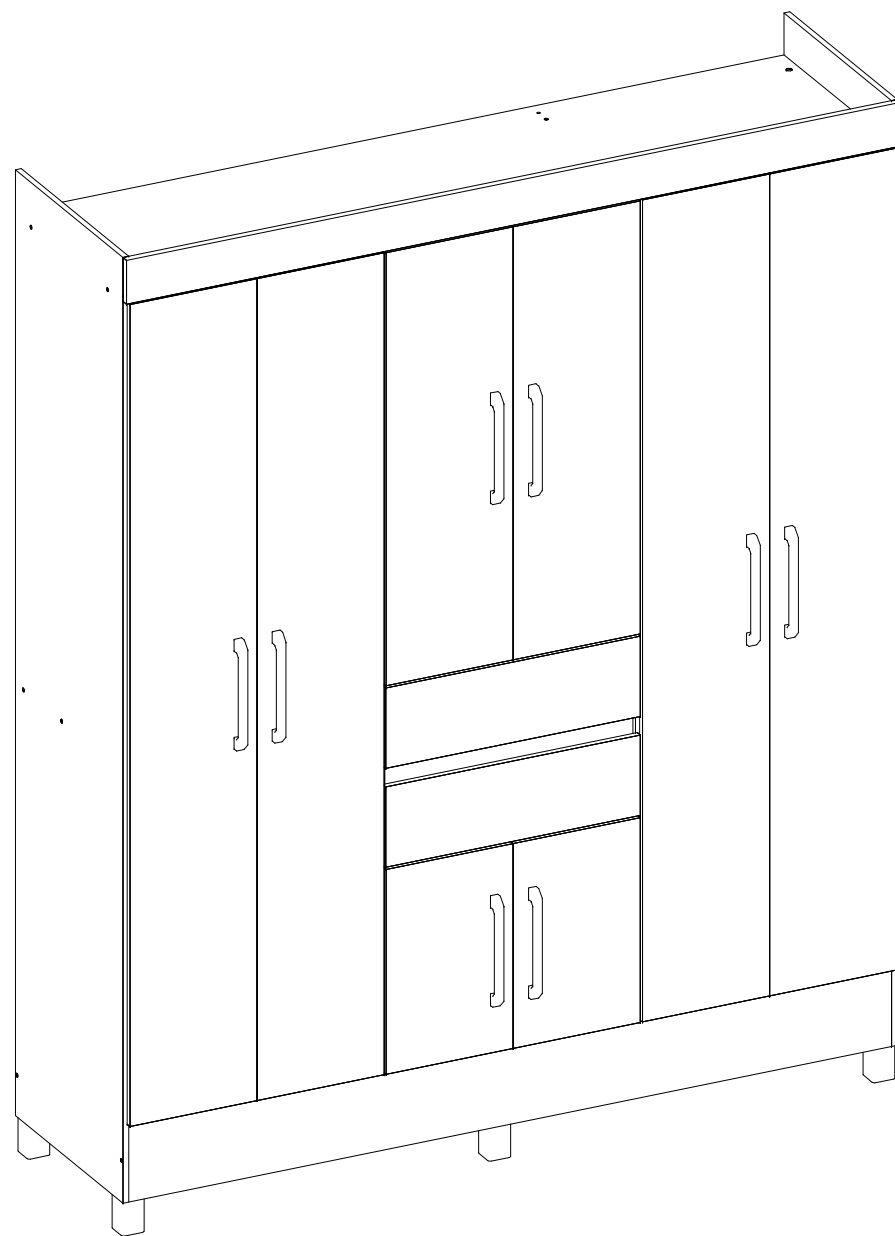

DEMÓBILE



82060 GR CASAL 08 PORTAS MUNIQUE

82060 WARDROBE 08 DOORS MUNIQUE

82060 CLOSET 08 PUERTAS MUNIQUE

GUARDA ROUPA CASAL 08 PORTAS MUNIQUE
 WARDROBE 08 DOORS MUNIQUE
 CLOSET 08 PUERTAS MUNIQUE

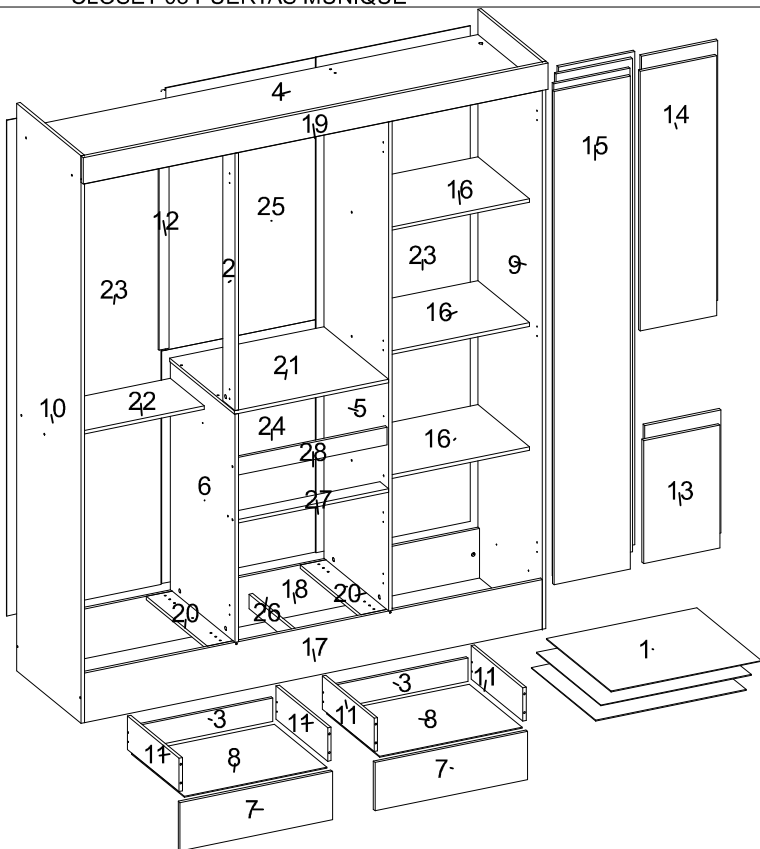

SEQ.	CODIGO	REF_01	REF_02	REF_03	REF_04	REF_05	REF_06	DESCRIÇÃO	DESCRIPTION_EN	DESCRIPCION_ES	DIMENSÕES_MM	QTD
1	03096	03	113	112	-	-	-	BASE	BASE	BASE	524 X 450 X 3	3
2	03087	03	113	112	-	-	-	BATENTE FRONTAL	FRONT SUPPORT	SDPORTE FRONTAL	880 X 85 X 12	1
3	06094	03	113	112	-	-	-	CONTRA FUNDO	DRAWER BACK	CONTRA FONDO	475 X 80 X 12	2
4	07080	03	113	112	-	-	-	CHAPEU	TOP PANEL	TAPA SUPERIOR DEL ROPEIRO	1596 X 450 X 12	1
5	08208	03	113	112	-	-	-	DIVISAO DIREITA DA GAVETA	RIGHT DIVISION	DIVISION DERECHA	1672 X 450 X 12	1
6	08209	03	113	112	-	-	-	DIVISAO ESQUERDA DA GAVETA	LEFT DIVISION	RIGHT DIVIDE	780 X 450 X 12	1
7	09123	03	106	105	-	-	-	FRENTE DE GAVETA	DRAWER FRONT	FRENTE DEL CAJON	532 X 165 X 12	2
8	10008	03	113	112	-	-	-	FUNDO GAVETA	DRAWER BASE	FONDO DEL CAJON	497 X 368 X 3	2
9	11254	03	111	110	-	-	-	LATERAL DIREITA	RIGHT SIDE PANEL	LATERAL DERECHA	1940 X 450 X 12	1
10	11255	03	111	110	-	-	-	LATERAL ESQUERDA	LEFT SIDE PANEL	LATERAL IZQUIERDA	1940 X 450 X 12	1
11	12004	03	113	112	-	-	-	LATERAL DE GAVETA	DRAWER SIDE	LATERAL DEL CAJON	360 X 114 X 12	4
12	13026	03	113	112	-	-	-	PERFIL H 35MM 880 MM	PROFILE H	PERFIL H	880 X 35 X 15	1
13	14201	03	106	105	-	-	-	PORTA SAPATEIRA	DOOR	PUERTA	420 X 266 X 12	2
14	14202	03	106	105	-	-	-	PORTA CENTRAL	DOOR	PUERTA	888 X 266 X 12	2
15	14203	03	106	105	-	-	-	PORTA LATERAL	DOOR	PUERTA	1686 X 266 X 12	4
16	15109	03	113	112	-	-	-	PRATELEIRA	SHELF	ESTANTERIA	524 X 360 X 12	3
17	16242	03	106	105	-	-	-	RODAPE FRONTAL	BOTTOM BOARD FRONT	ZÓCALO FRONTAL	1596 X 170 X 12	1
18	16243	20	20	20	-	-	-	RODAPE TRASEIRO	BOTTOM BOARD BACK	ZÓCALO TRASERO	1596 X 170 X 12	1
19	17067	03	106	105	-	-	-	RODATETO	TOP FRONT BOARD	MOLDURA SUPERIOR	1620 X 90 X 15	1
20	18009	20	20	20	-	-	-	SUPORTE DA BASE	DRAWER SUPPORT	SDPORTE DE BASE	425 X 110 X 12	2
21	19164	03	113	112	-	-	-	TAMPO GAVETEIRO	DRAWER CABINET TOP PANEL	TAPA DEL CAJÓN	538 X 450 X 12	1
22	19165	03	113	112	-	-	-	TAMPO CALÇEIRO	SHELF	ESTANTERIA	524 X 235 X 12	1
23	20262	03	113	112	-	-	-	TRASEIRO LATERAL	BACK PANEL	TRASERO	1694 X 538 X 3	2
24	20263	03	113	112	-	-	-	TRASEIRO GAVETEIRO CENTRAL	BACK PANEL	TRASERO	795 X 535 X 3	1
25	20264	03	113	112	-	-	-	TRASEIRO CENTRAL	BACK PANEL	TRASERO	896 X 522 X 3	1
26	24011	20	20	20	-	-	-	APOIO DO PE	PE SUPPORT	APOYO DEL PE	425 X 50 X 12	1
27	29052	03	113	112	-	-	-	VISTA DA PORTA	DRAWER'S SECURITY SUPPORT	TRAVESA DE CAJÓN	524 X 60 X 12	1
28	29053	03	111	110	-	-	-	VISTA DA GAVETA	FRONT CRANKCASE	TRAVESA FRONTAL	524 X 60 X 12	1

DEMÓBIL Indústria de Móveis Ltda.
 Rua : Jurutau, 1350 - Pq. Industrial II,
 Cep.: 86703-070
 Arapongas - PR - Brasil
 demobile@demobile.com.br

90 DIAS GARANTIA

- Avisos**
1. Ler atentamente as instruções do manual antes de iniciar a montagem do móvel.
 2. A montagem deverá ser feita em superfície limpa e plana, aconselhamos forrar o chão com a embalagem do produto, para não danificar.
 3. Os parafusos devem ser apertados periodicamente.
 4. Evitar batidas e contato com objetos cortantes.
 5. O peso máximo de carga informado refere-se a objetos distribuídos de maneira uniforme sobre toda área de contato da peça.
- Limpeza e Conservação
 Efetuar a limpeza somente com pano macio limpo e seco.
 Não Utilizar produtos abrasivos ou químicos.
- Garantia
 1. O fabricante responsabiliza-se apenas pelas peças do produto.
 2. A montagem incorreta acarretará na perda da garantia e das assistências, desta forma o produto deverá ser montado por profissional qualificado.
 3. Não estão cobertos pela garantia problemas que tenham origem na utilização inadequada do produto ou na exposição do mesmo a intempéries como: infiltrações, infestação de pragas em geral, aparecimento de mofo e outros, decorrentes do ambiente de instalação.

Assistência Técnica: Em caso de peças em assistência técnica é necessário que as mesmas sejam solicitadas junto a loja ou site no qual a compra do produto foi realizada.

- Warnings**
1. Read the manual instructions carefully before starting to assemble the furniture.
 2. The assembly must be done in clean and flat surface, we advise to put the product packaging on the floor, not to damage it during the assembling.
 3. The screws must be tightened periodically.
 4. Avoid hitting and contacting sharp objects.
 5. The payload informed refers to the objects distributed all over the piece contact area.
- Cleaning and conservation
 Clean the product just with a soft, cleaned and dry cloth.
 Do not use abrasive or chemicals products.
- Warranty
 1. The manufacturer is only responsible for product parts.
 2. Incorrect assembling will make you lost the guarantee and assistance, in this way the product must be assembled by qualified professional.
 3. It is Not covered by the warranty problems caused by an inappropriate use of the product or product exposure even in bad weather, such as: infiltrations, pest infestation in general, appearance of mold and others, caused by the installation environment.

Technical Assistance: Damaged pieces! Ask on the stores you bought it.

- Advertencias**
1. Lea atentamente las instrucciones del manual antes de empezar a armar los muebles.
 2. El montaje debe hacerse en superficie limpia y plana, utilice el empaque del Producto para cubrir el piso.
 3. Los tornillos deben ser apretados periodicamente
 4. Evite golpear y chocar objetos punzantes
 5. El peso máximo de carga tiene relación a los objetos distribuidos sobre toda el área de contacto de la pieza.
- Limpeza y conservación
 Limpiar solo con un trapo suave, limpio y seco
 No utilice productos abrasivos o productos químicos
- Garantía
 1. El fabricante solo es responsable a las partes del producto.
 2. Armar incorrectamente supone la pérdida de garantía y repuestos, de esta manera el producto debe ser ensamblado por profesional calificado.
 3. No es garantado problemas derivados del uso inapropiado del producto, o exposición del producto al mal tiempo, como: infiltraciones, infestación de plagas en general, aparición de moho y otros.

Asistencia técnica: en caso de piezas rotas es necesario que sea solicitadas las mismas a la tienda o sitio web donde se compró el producto.

COMPLETE MANUAL
 MANUAL COMPLETO

Acessórios/Acessories/Acessorios

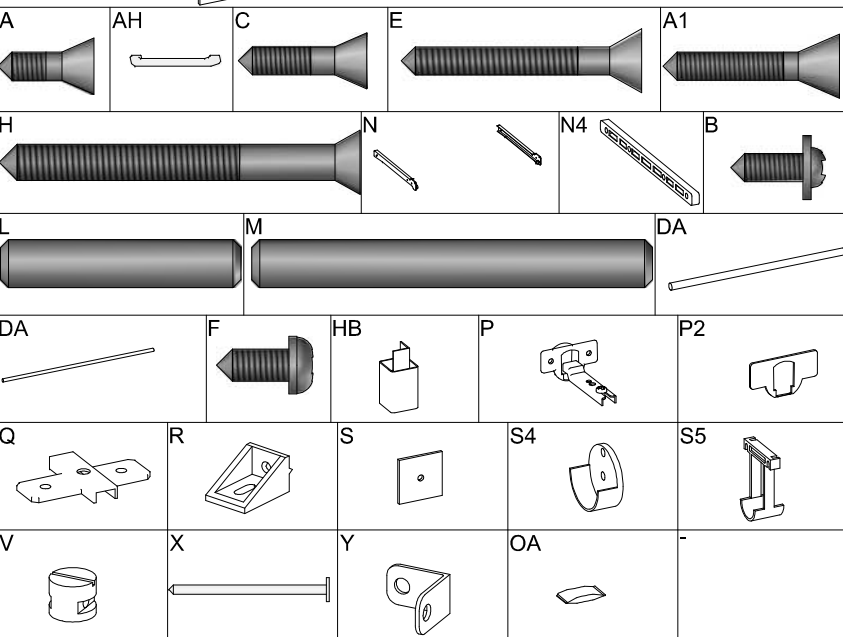

LISTA DE ACESSÓRIOS / LIST OF ACCESSORIES / LISTA DE ACCESORIOS

SEQ.	CODIGO	DESCRIÇÃO	DESCRIPTION_EN	DESCRIPCION_ES	QTD.
A	9905002	PARAFUSO 3.5 X 12 MM CHATA PHILIPS	PHILIPS FLAT HEAD SCREW	TORNILLO CHATA PHILIPS	38
AH	9905023	PARAFUSO 3.5 X 22 MM CHATA PHILIPS	PHILIPS FLAT HEAD SCREW	TORNILLO CHATA PHILIPS	2
H	9904006	PUXADOR ECON F 192 MM CROMADO	HANDLE	TIRADOR	8
B	9905003	PARAFUSO 3.5 X 12 MM FLANGEADO PHILIPS	PHILIPS FLANGE SCREW	TORNILLO DE BRIDA PHILIPS	32
C	9905004	PARAFUSO 3.5 X 16 MM CHATA PHILIPS	PHILIPS FLAT HEAD SCREW	TORNILLO CHATA PHILIPS	22
DA	9901062	CABIDEIRO REDONDO 1050 MM MADEIRA	HANGER	PERCHERO	1
DA	9901063	CABIDEIRO REDONDO 516 MM MADEIRA	HANGER	PERCHERO	1
E	9905020	PARAFUSO 3.5 X 30 MM CHATA PHILIPS	PHILIPS FLAT HEAD SCREW	TORNILLO CHATA PHILIPS	24
F	9905007	PARAFUSO 4 X 12 MM PANELA PHILIPS	PANHEAD SCREW	TORNILHO CABEZEIRA DE OLHA	80
H	9905015	PARAFUSO 4.5 X 45 MM CHATA PHILIPS	PHILIPS FLAT HEAD SCREW	TORNILLO CHATA PHILIPS	40
HB	9918006	PE 47 X 47 X 100 MM PLASTICO ECONOMICO	PLASTIC FOOT	PATA DE PLASTICO	6
L	9920011	CAVILHAS 6 X 30 MM	WOODEN PEG	CLAVIJA DE MADERA	46
M	9920012	CAVILHAS 6 X 50 MM	WOODEN PEG	CLAVIJA DE MADERA	1
N	9913005	CORREDICA 350 MM METAL LIGHT	METAL SLIDE	RIEL METALICO	2
N4	9913007	CORREDICA 255 X 16 X 10 MM PLASTICA	PLASTIC RUMER	RIEL PLASTICO	2
OA	9912006	SACHET DE COLA	GLUE	COLA	1
P	9920020	DOBRADICA ALTA 26 MM ESTAMPADA	HINGE	BISAGRA	20
P2	9920064	DISTANCIADOR PARA DOBRADICA PLASTICO 26 MM	HINGE SPACER	DISTANCIADOR DE BISAGRA	20
Q	9920005	CALCO DOBRADICA 5 MM	HINGE SUPPORT	SOPORTE DE BISAGRA	20
R	9920025	FIXADOR 90 GRAUS	90 DEGREE FASTENER	FJADOR 90 GRADOS	4
S	9920026	FIXADOR DE FUNDO 10 X 10 MM	BOOTOM FASTENER	FJADOR DE FONDO	25
S4	9920037	SUPORTE CABIDEIRO MEIA CANA	HANGER SUPPORT	SOPORTE DE PERCHERO	4
S5	9920039	SUPORTE CABIDEIRO U	HANGER SUPPORT U	SOPORTE DE PERCHERO U	1
V	9920030	PORCA CILINDRICA PRATA	CYLINDRICAL NUT	TUERCA CILINDRICA	36
X	9906002	PREGO 9X9 MM	NAIL	CLAVO	110
Y	9920006	CANTONEIRA METALICA 16 MM	METAL ANGLE BRACKET	ESQUINERAS METALICAS	6

01

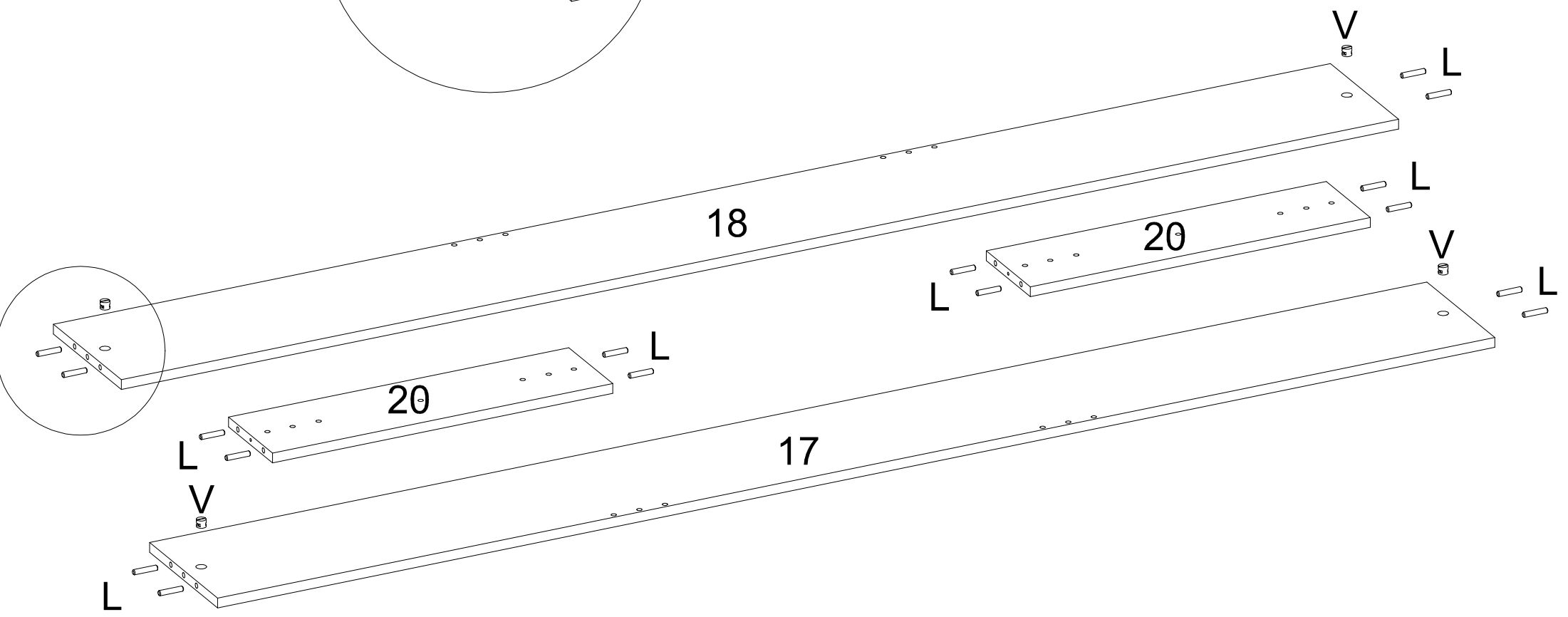
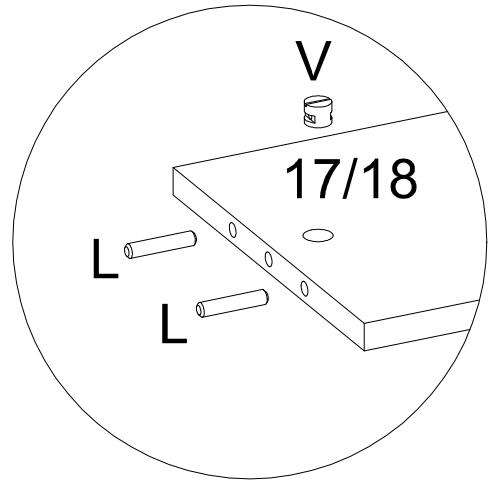

L	X16	V	X4	-	-	-	-	-	-
---	-----	---	----	---	---	---	---	---	---

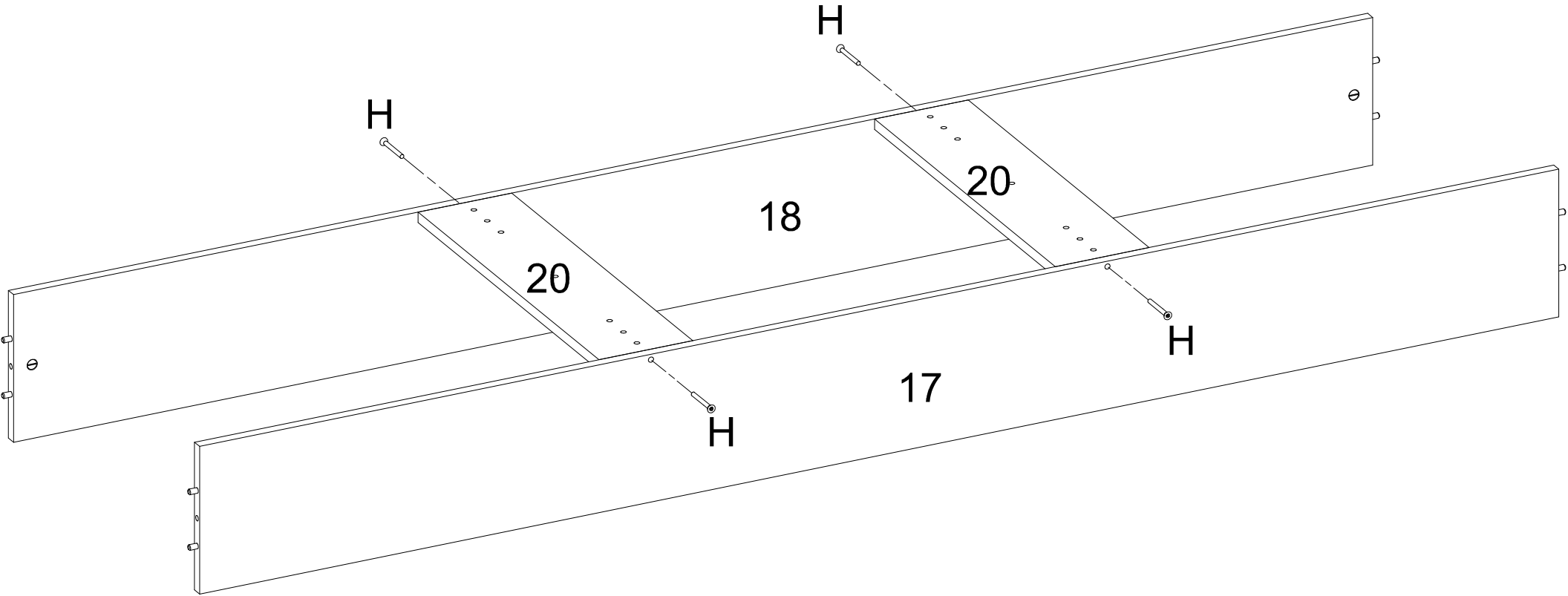

H	-	-	-	-	-	-	-
X4	-	-	-	-	-	-	-

03

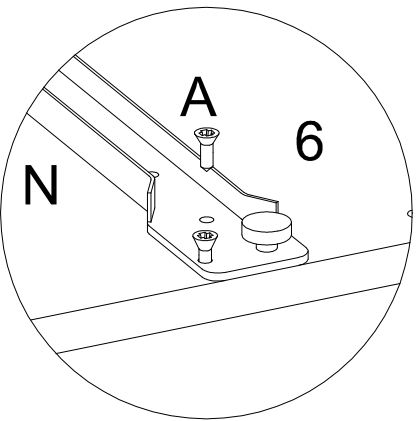
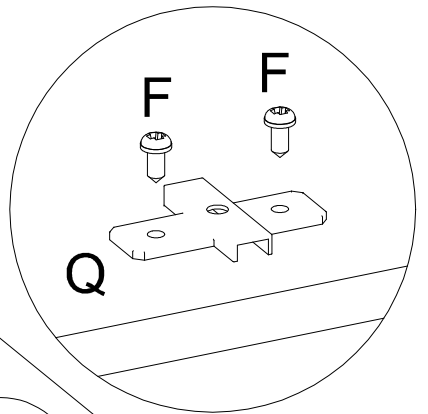
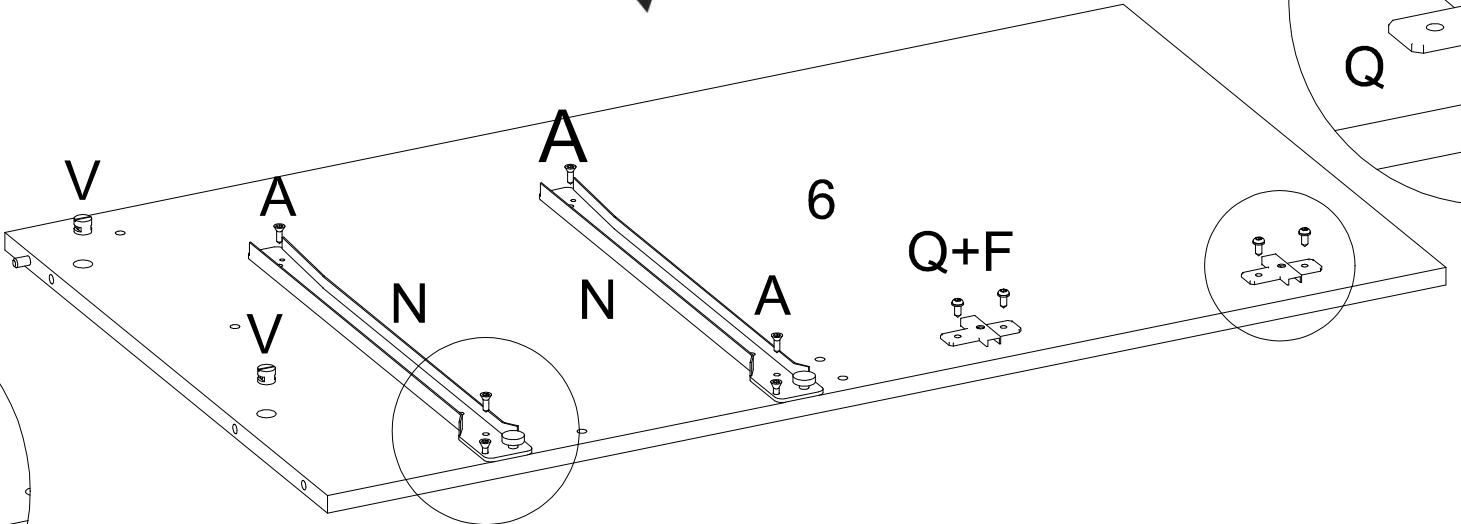
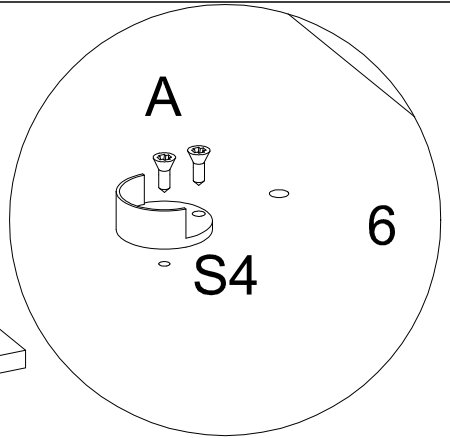
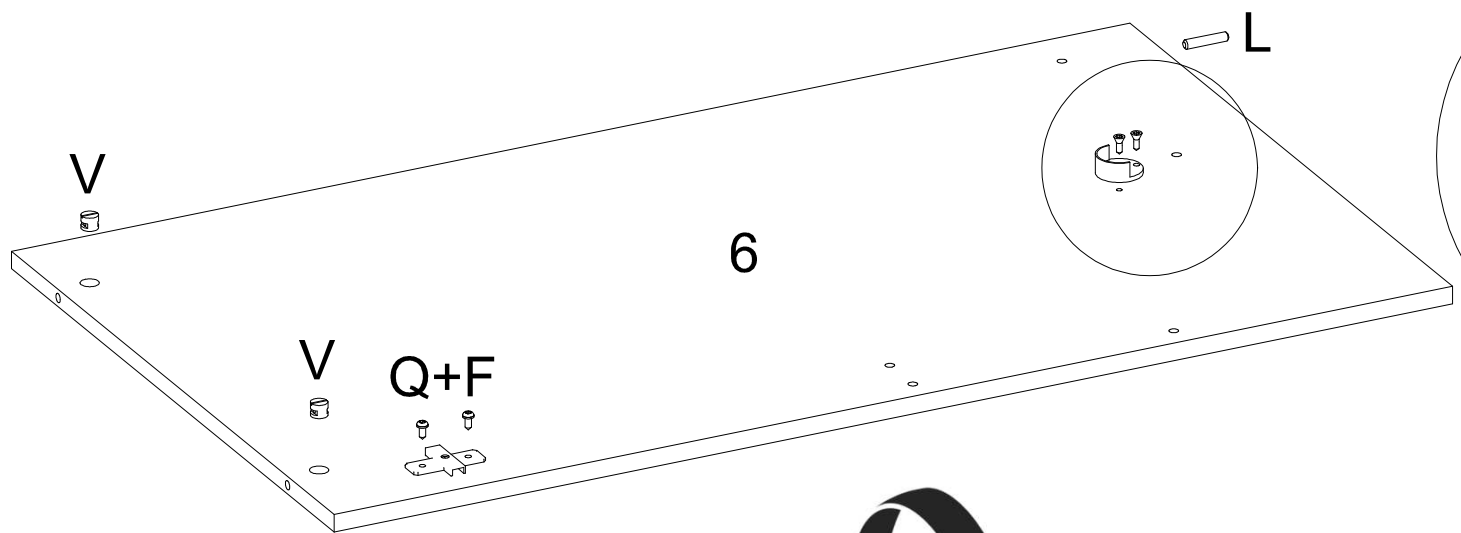

V	Q	F	S4	L	A	N	-
X4	X3	X6	X1	X1	X8	X2	-

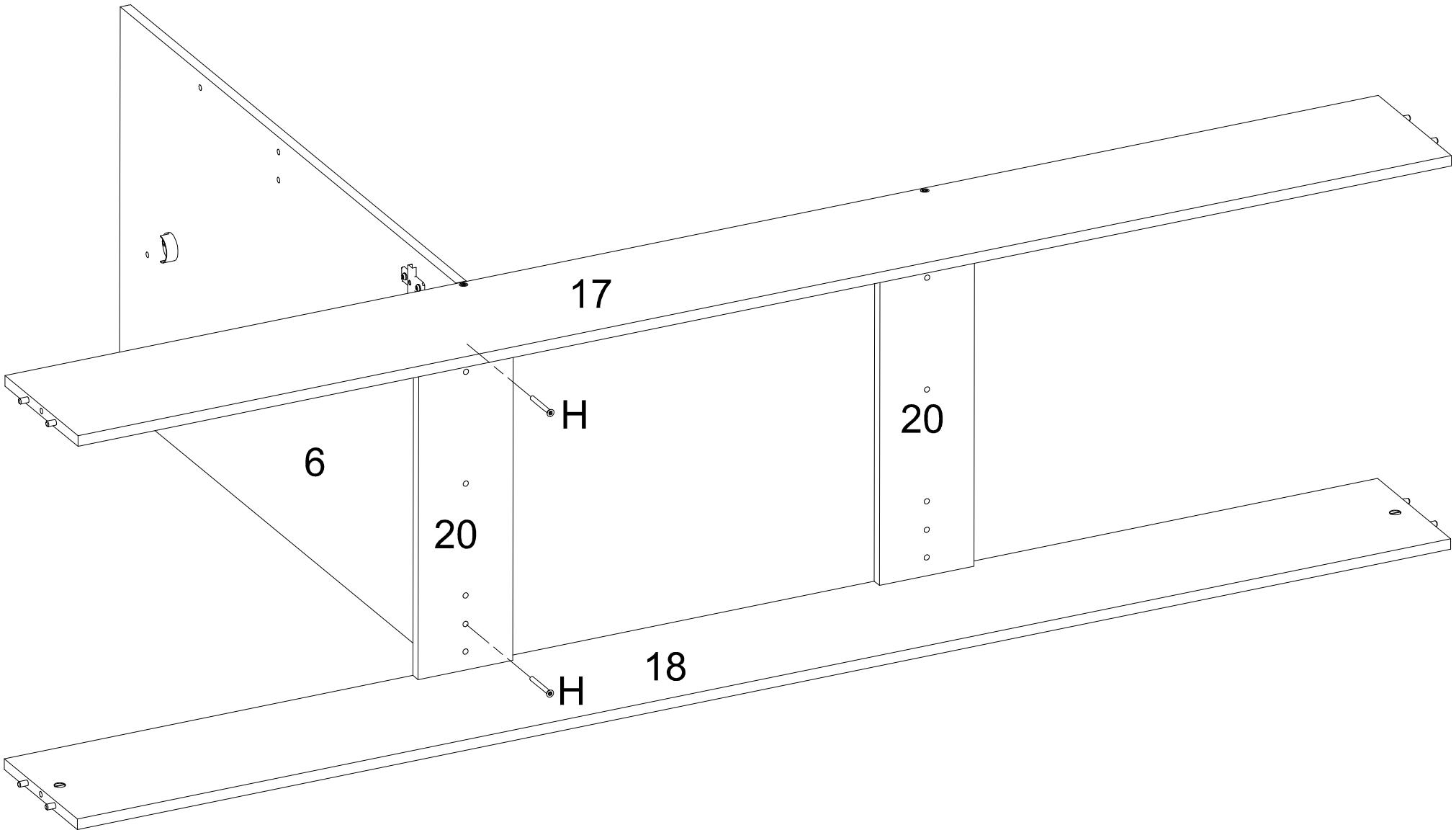

H	-	-	-	-	-	-	-
X2	-	-	-	-	-	-	-

05

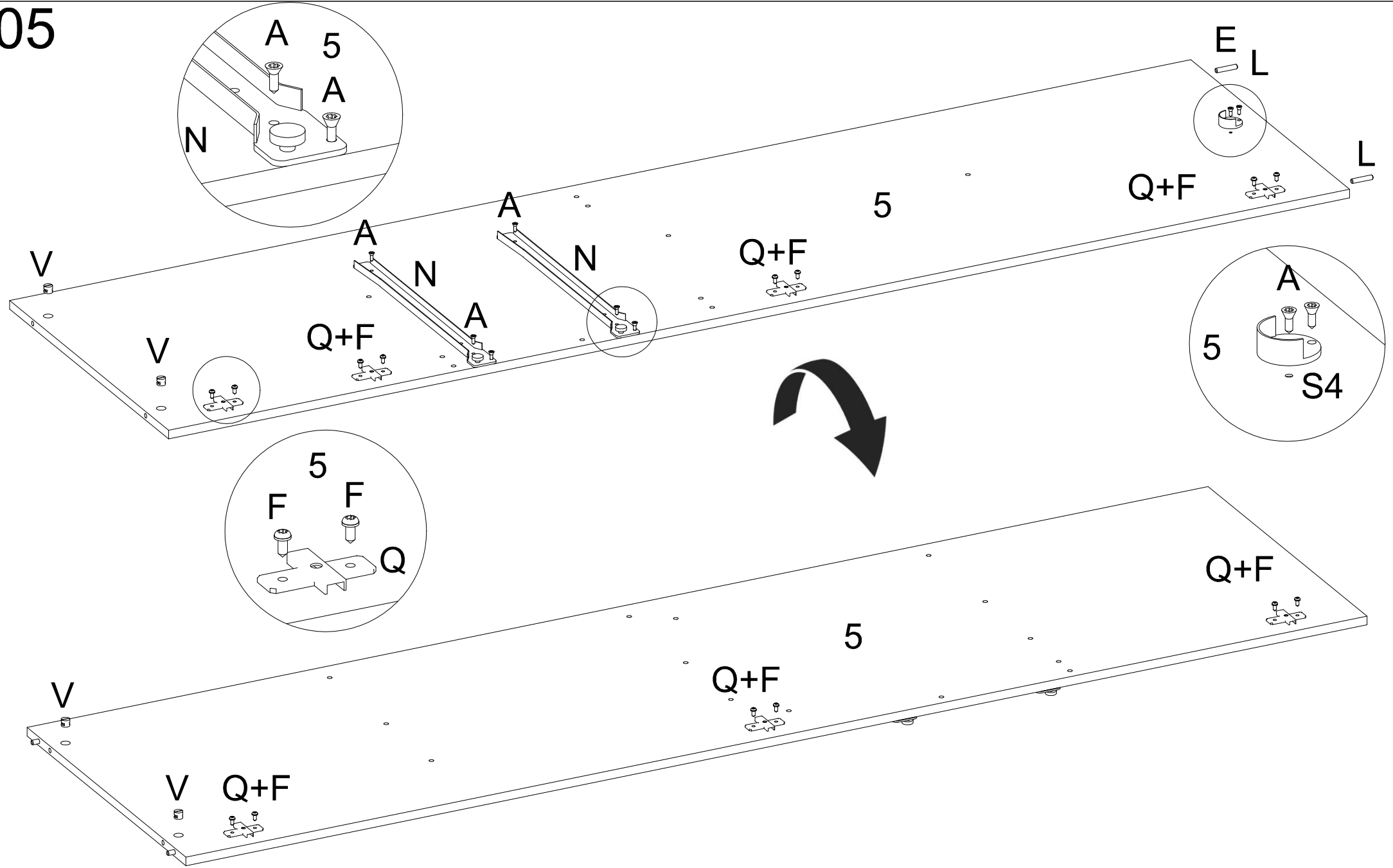

V	Q	F	A	N	S4	L	-
X4	X7	X14	X8	X2	X1	X2	-

06

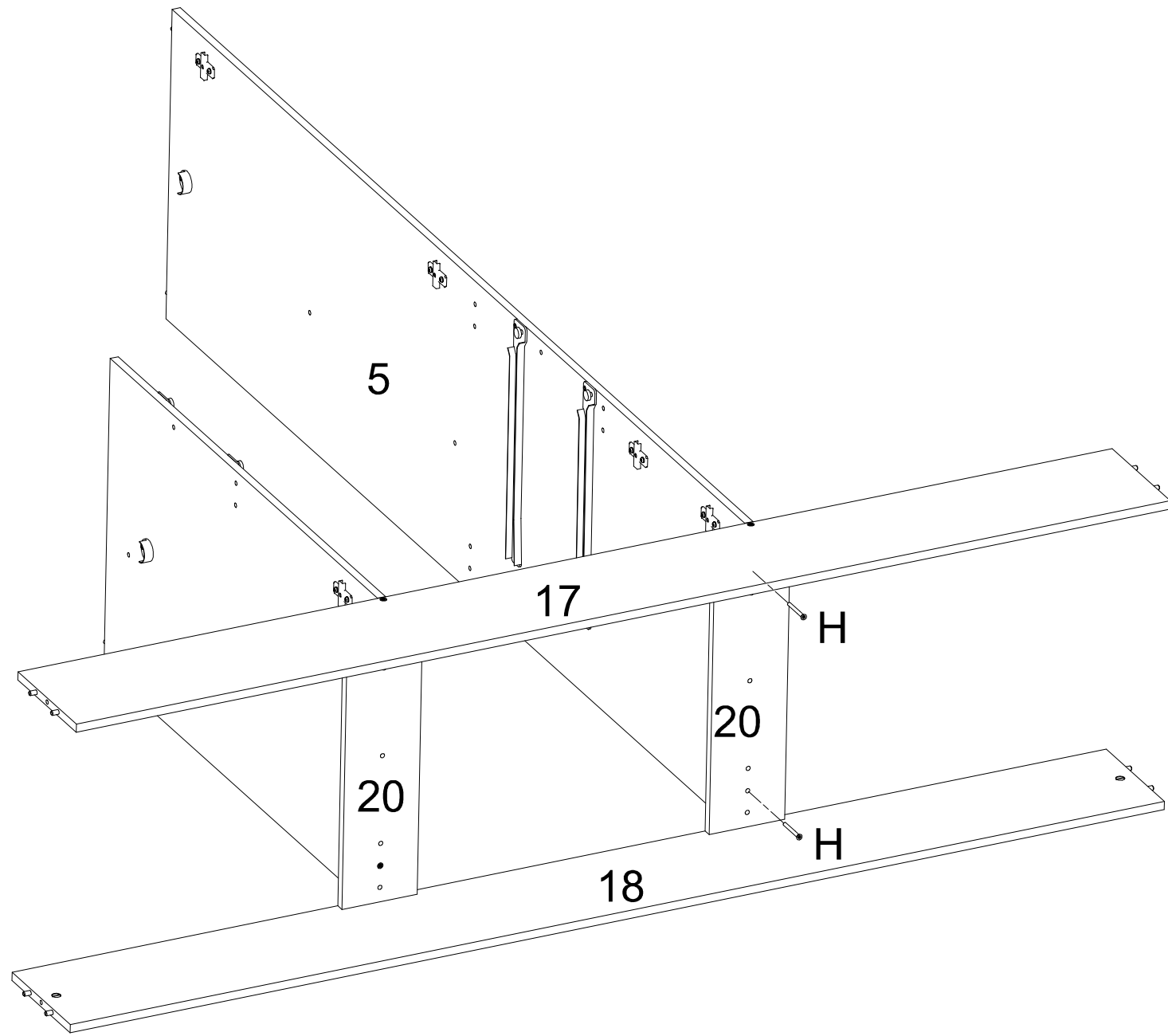

H	-	-	-	-	-	-	-
X2	-	-	-	-	-	-	-

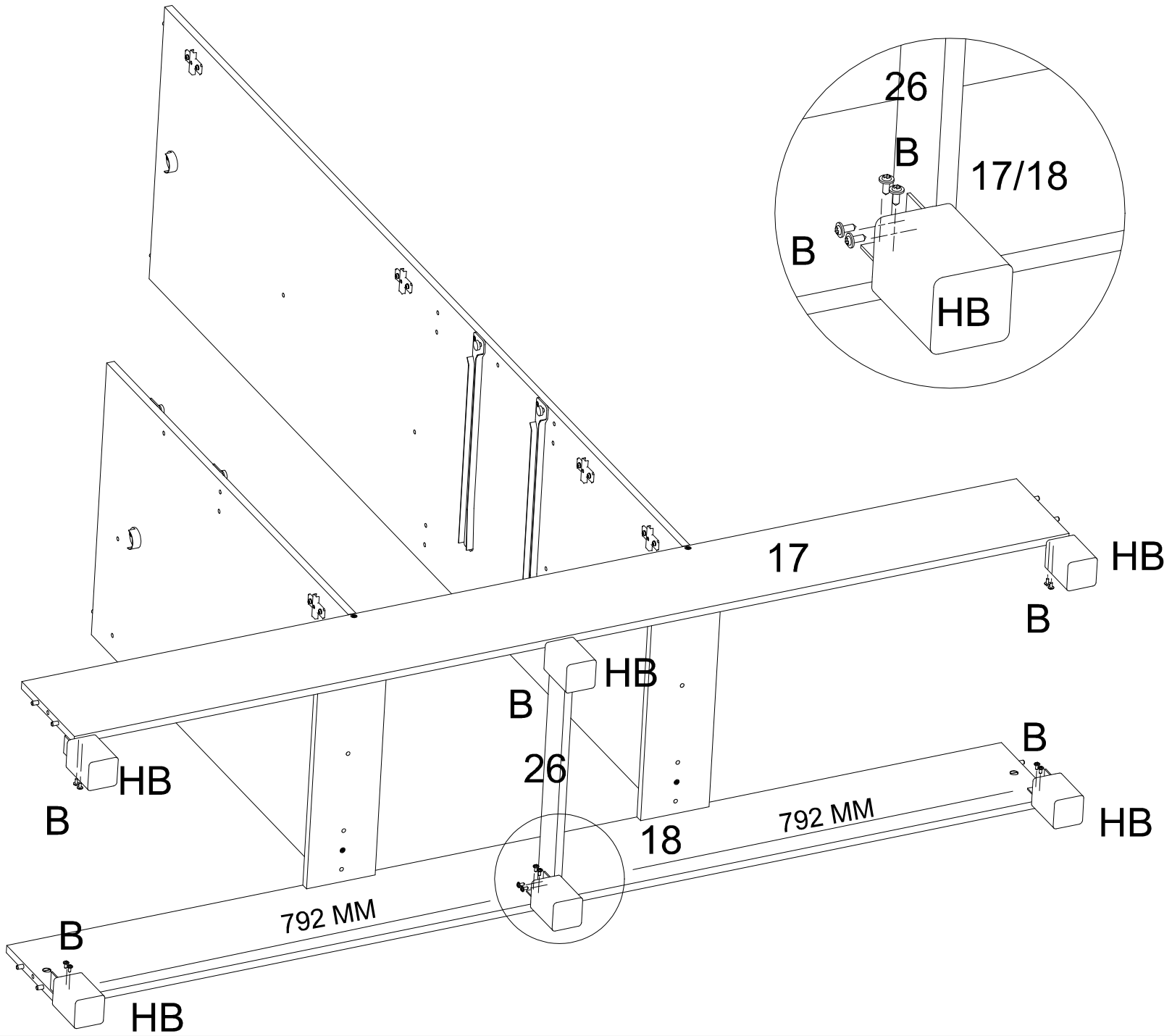

BH	B	-	-	-	-	-	-
X6	X16	-	-	-	-	-	-

08

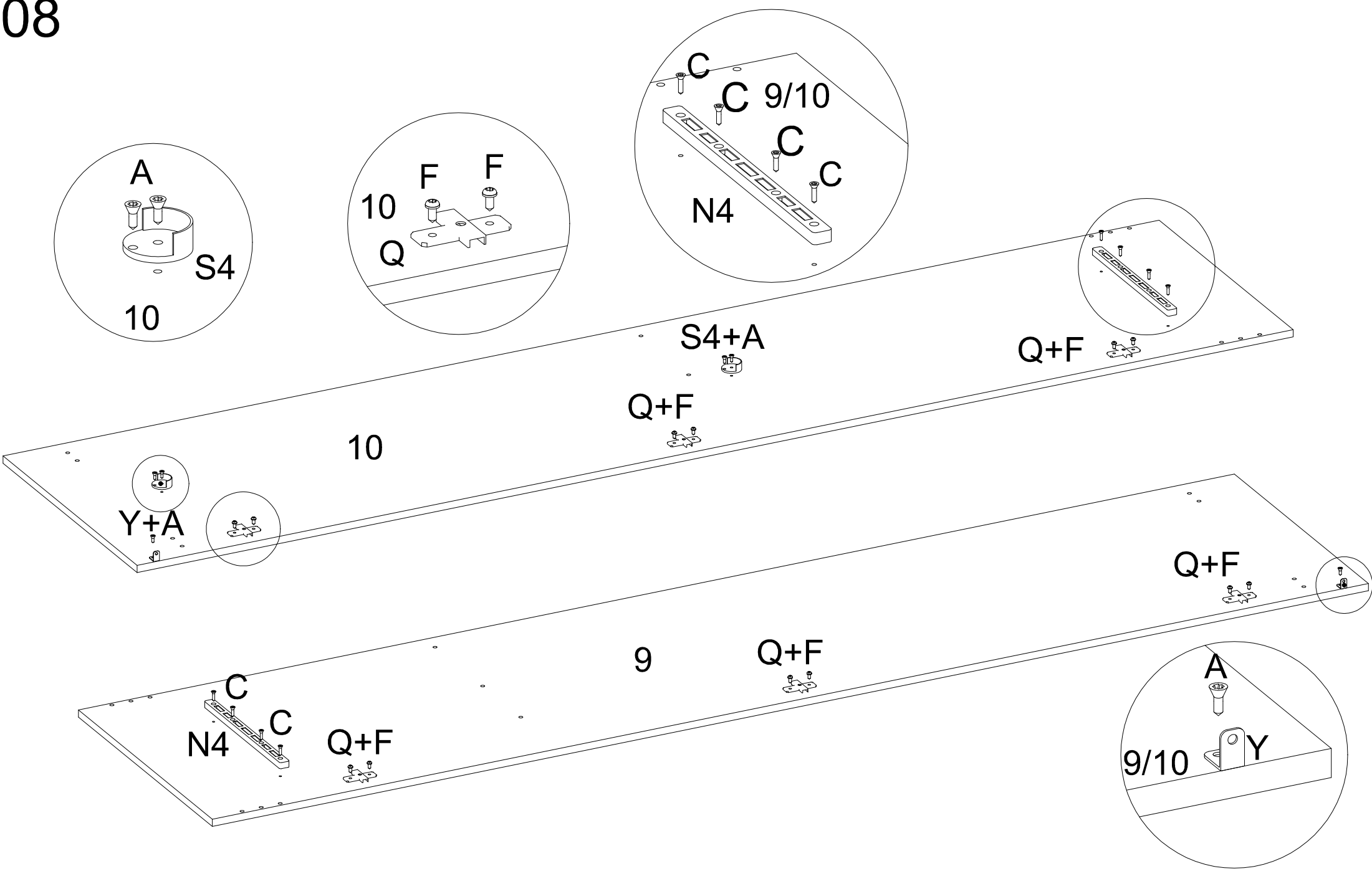

Q	F	C	N4	S4	Y	A	-
X6	X12	X8	X2	X2	X2	X6	-

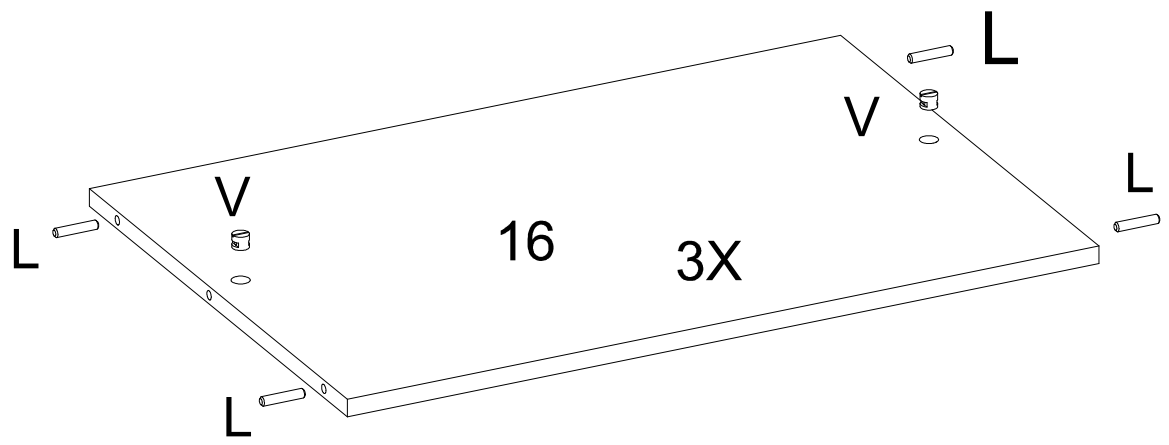
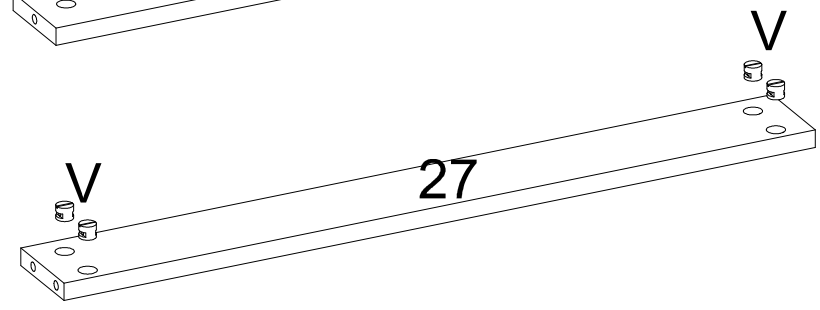
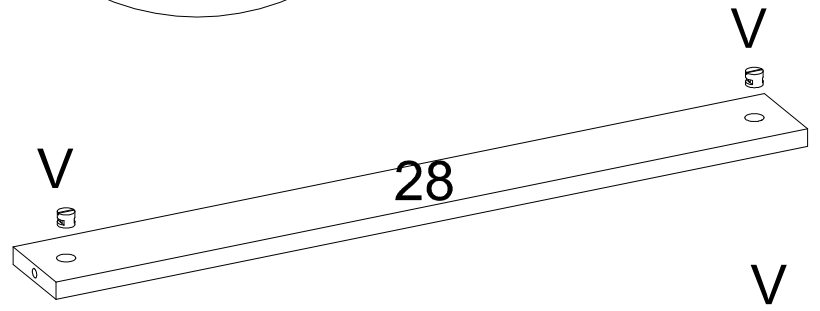
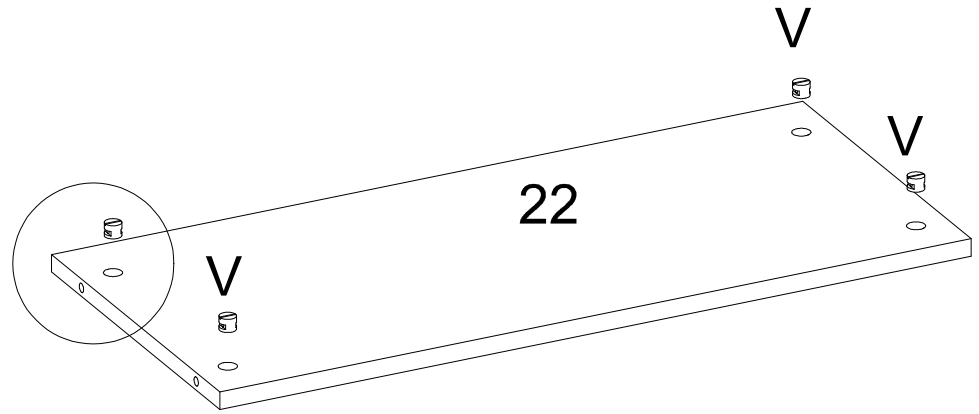
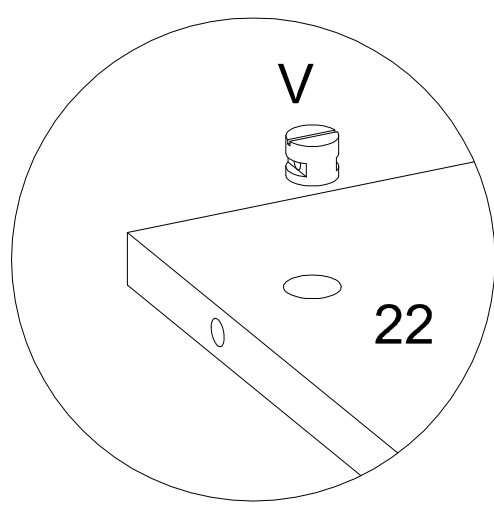

L	X12	V	X16	-	-	-	-	-	-
---	-----	---	-----	---	---	---	---	---	---

10

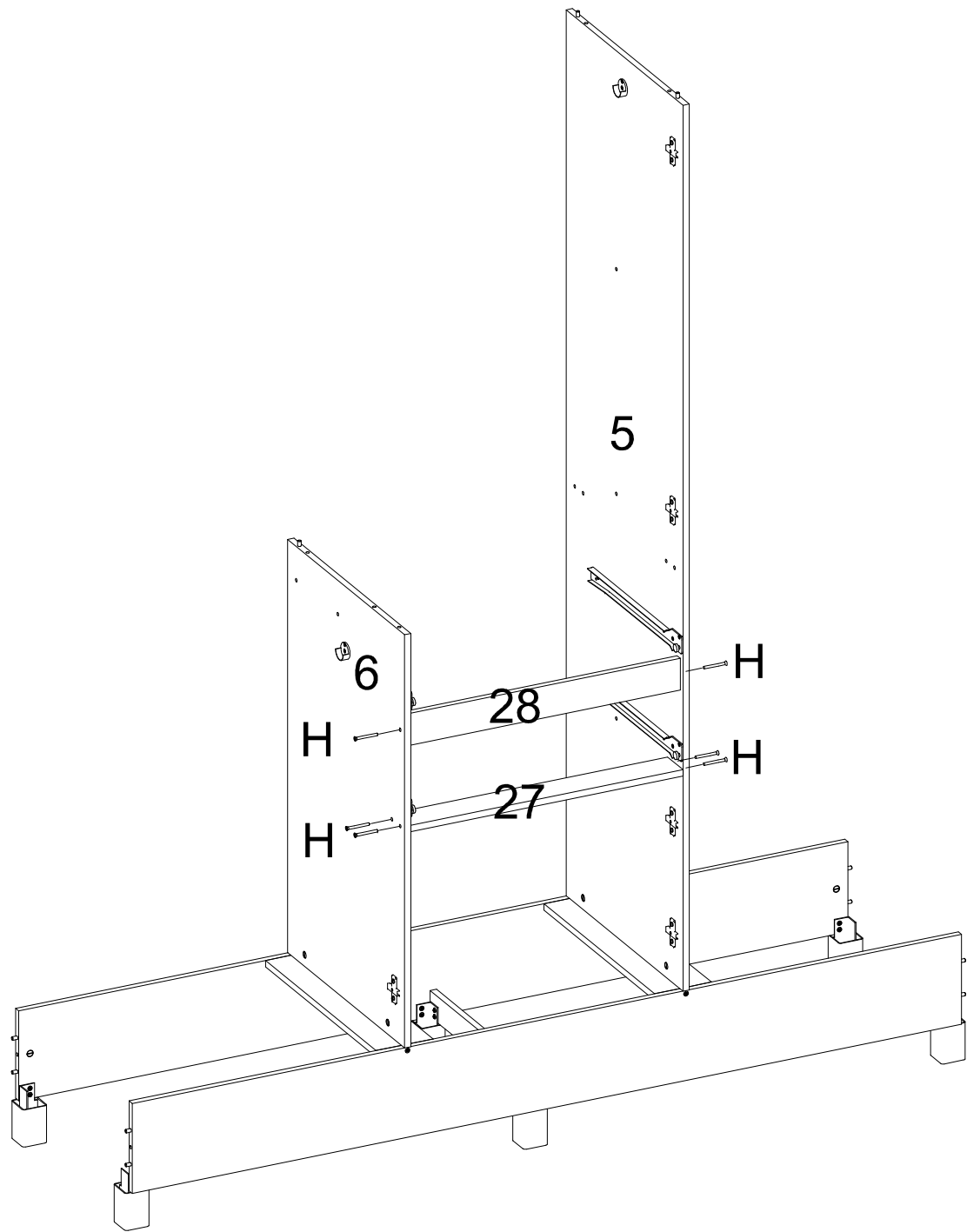

H	-	-	-	-	-	-	-
X6	-	-	-	-	-	-	-

11

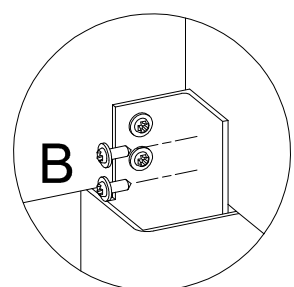
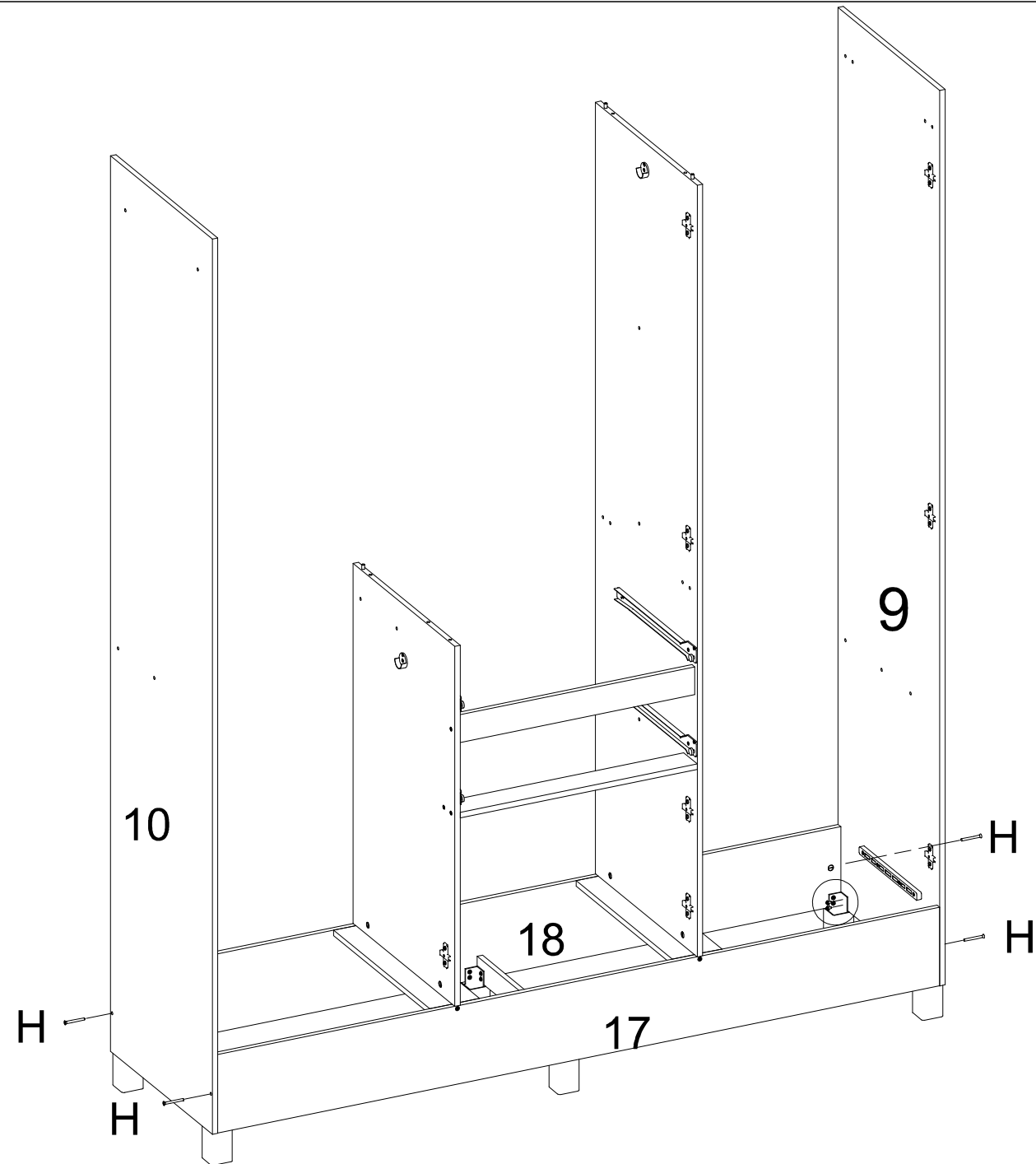

H	X4	B	X8	-	-	-	-	-	-
---	----	---	----	---	---	---	---	---	---

12

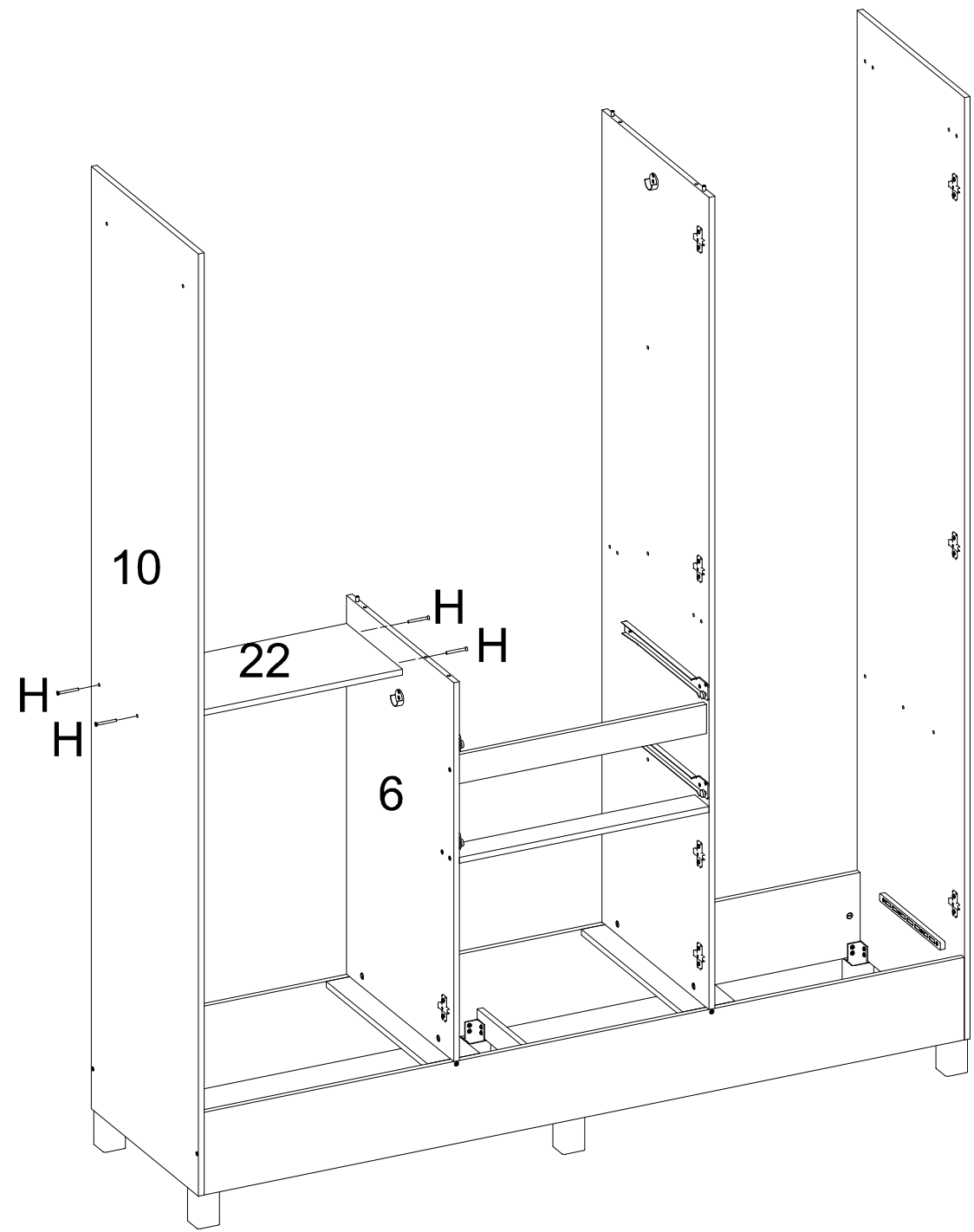

H	-	-	-	-	-	-	-
X4	-	-	-	-	-	-	-

13

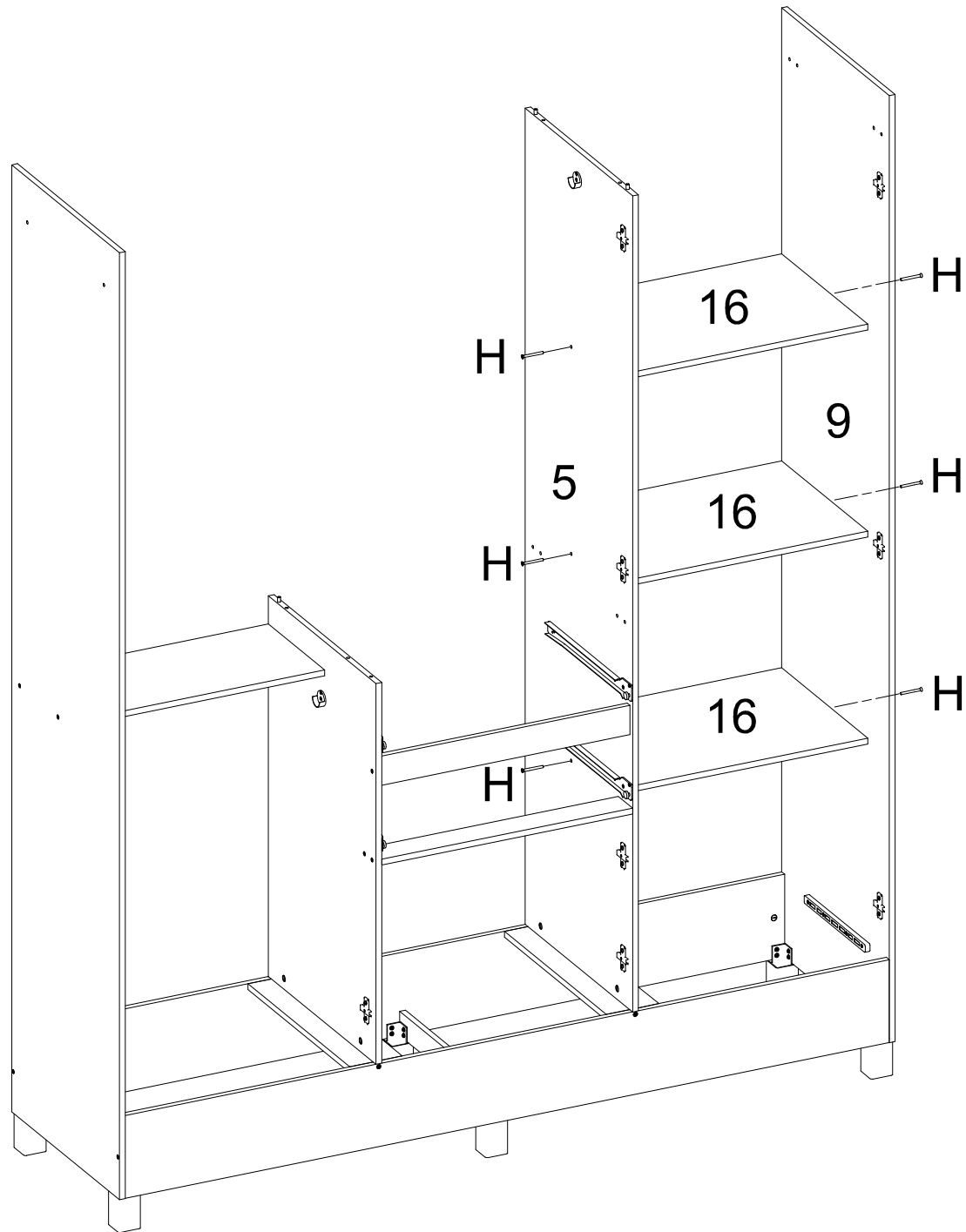

H	-	-	-	-	-	-	-
X6	-	-	-	-	-	-	-

14

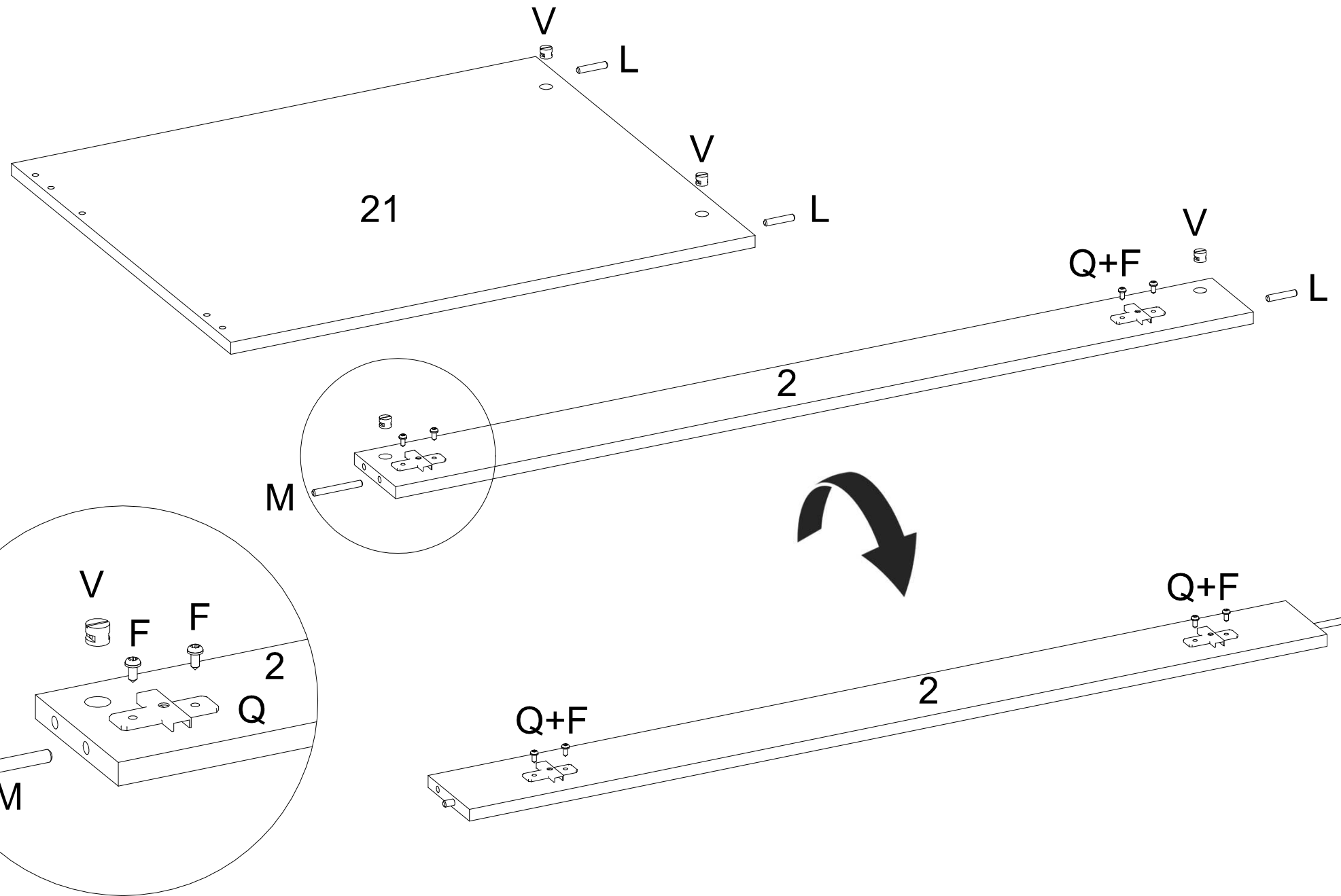

L	M	V	Q	F	-	-	-
X3	X1	X4	X4	X8	-	-	-

15

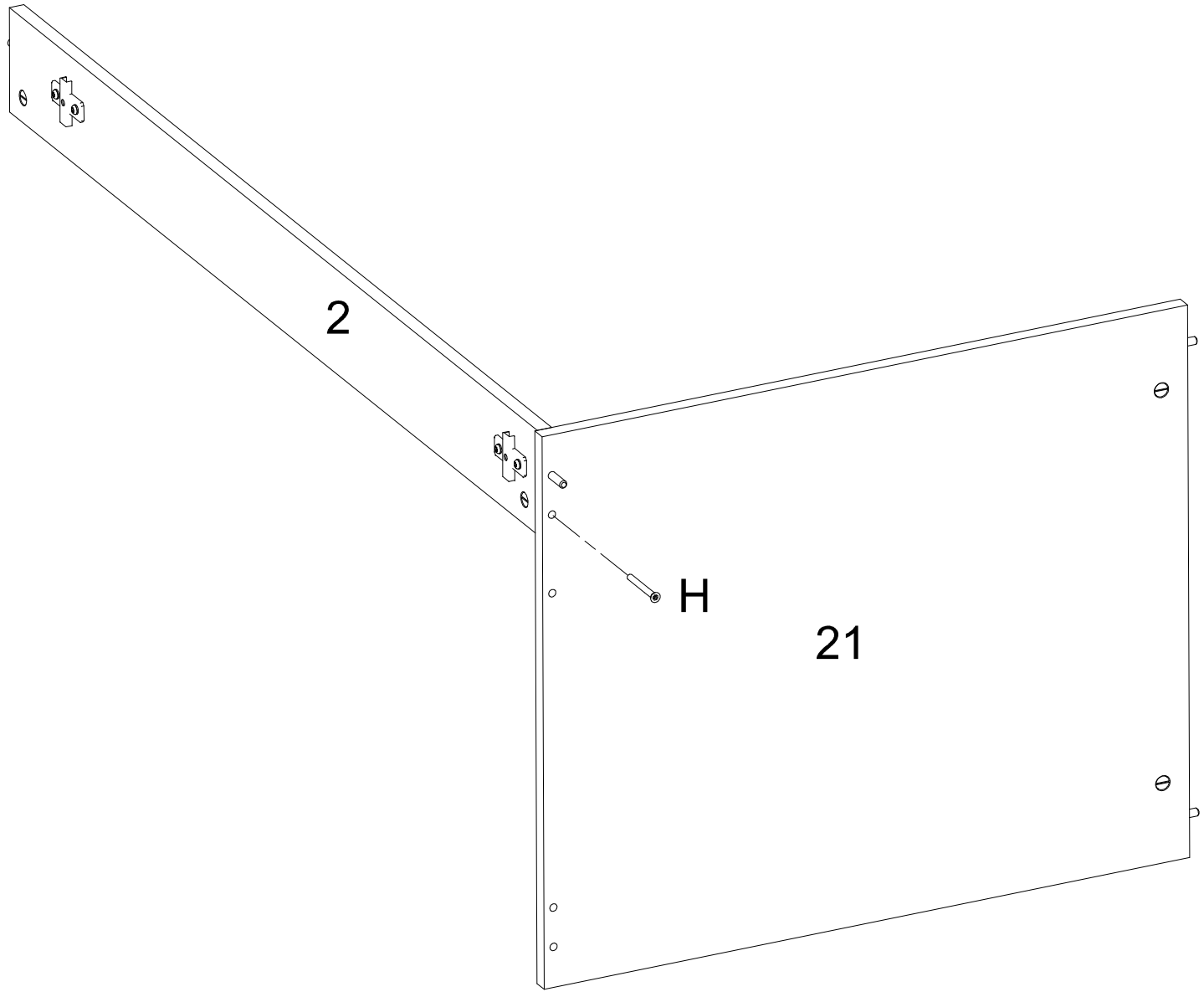

H	-	-	-	-	-	-	-
X1	-	-	-	-	-	-	-

16

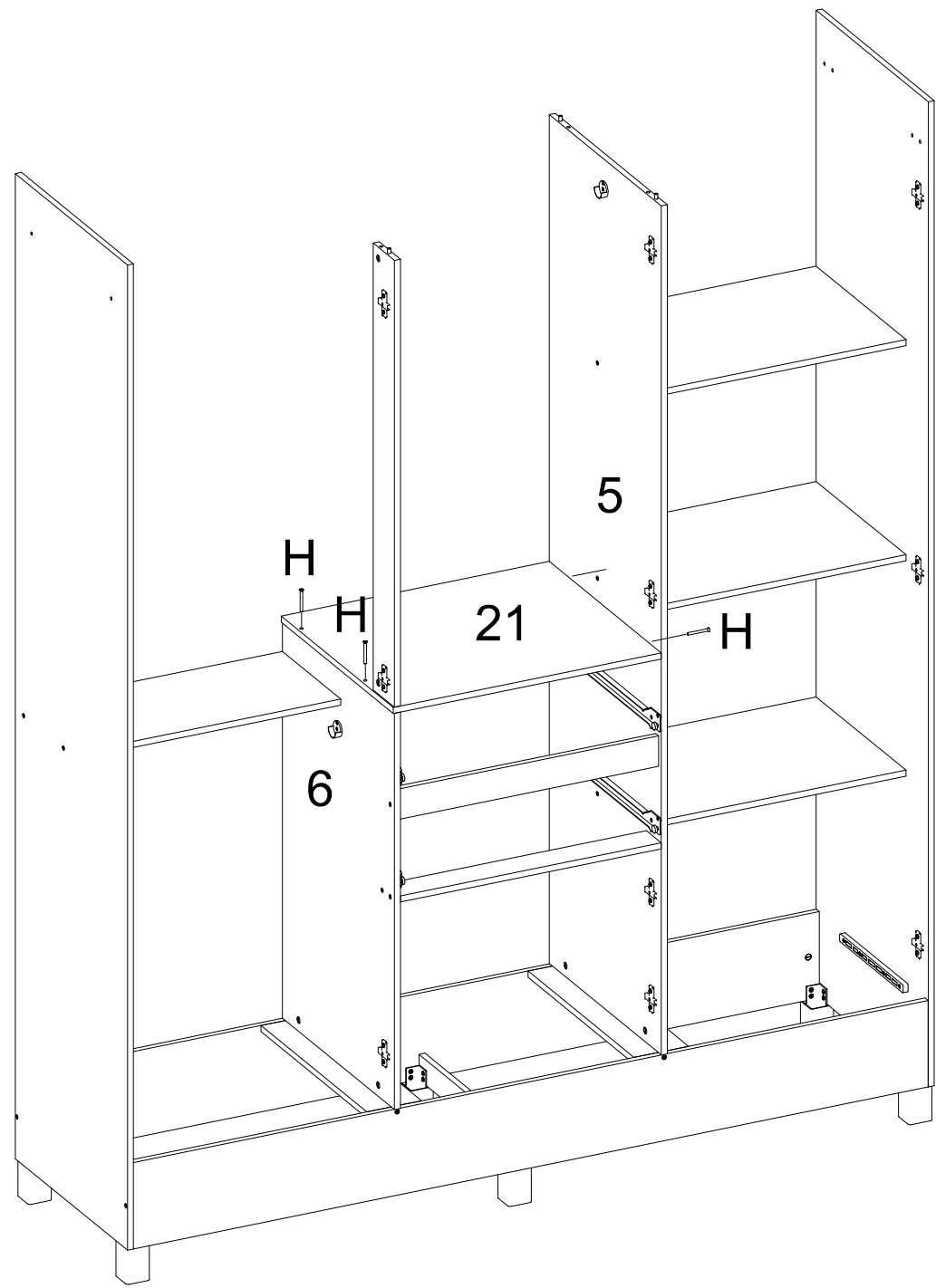

H	-	-	-	-	-	-	-
X4	-	-	-	-	-	-	-

17

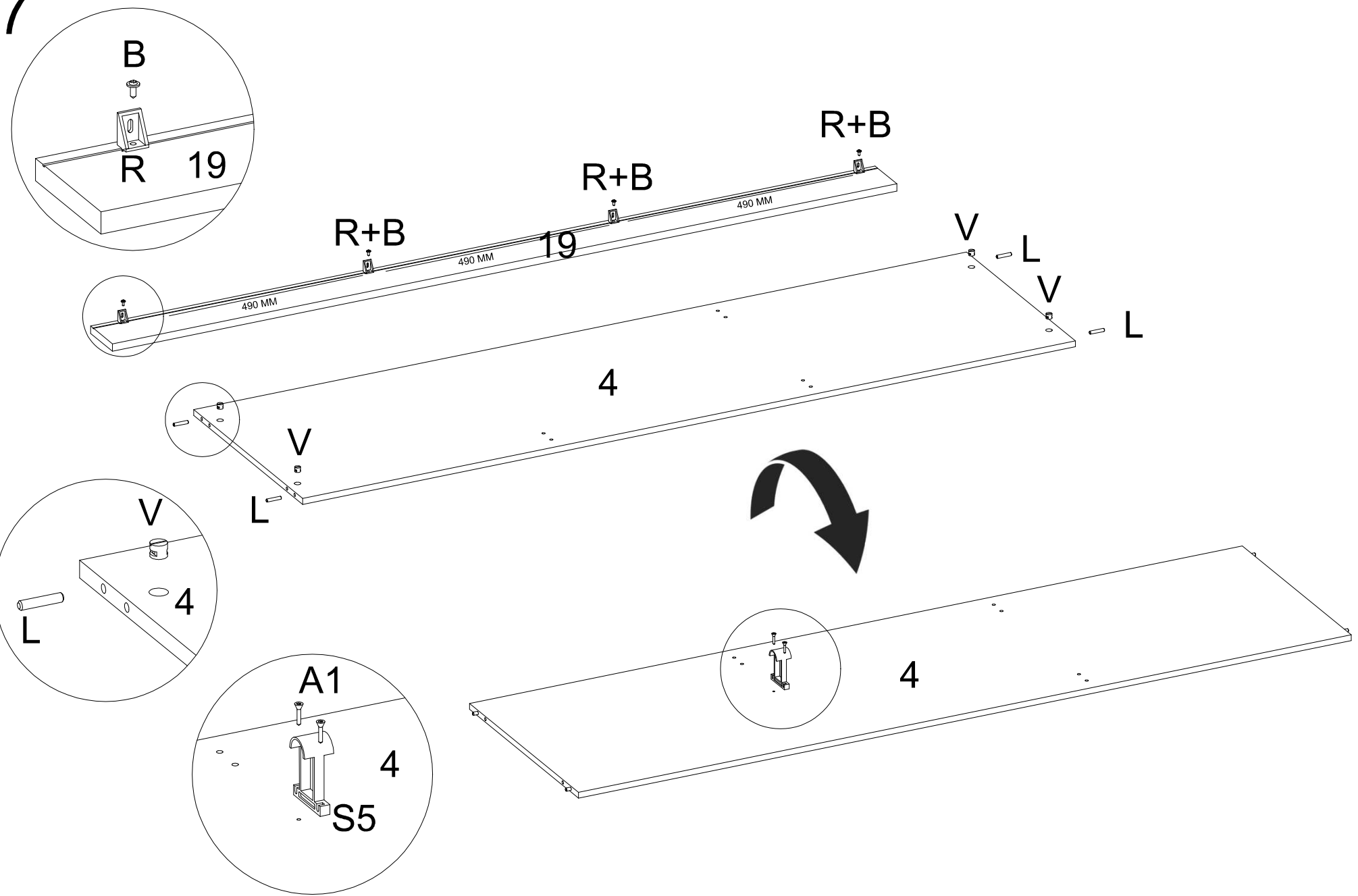

R	B	V	L	S5	A1	-	-
X4	X4	X4	X4	X1	X2	-	-

18

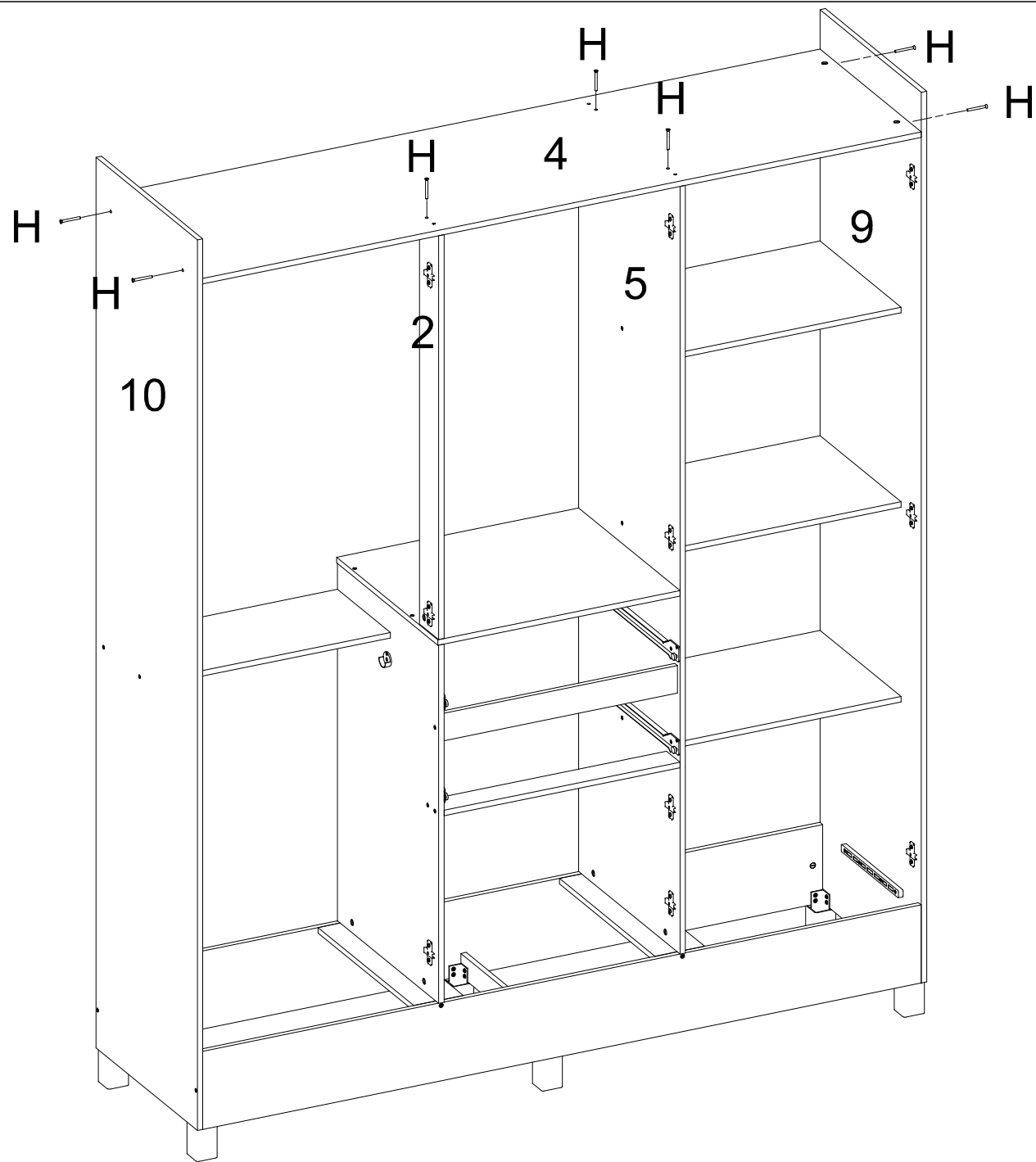

H	-	-	-	-	-	-	-
X7	-	-	-	-	-	-	-

19

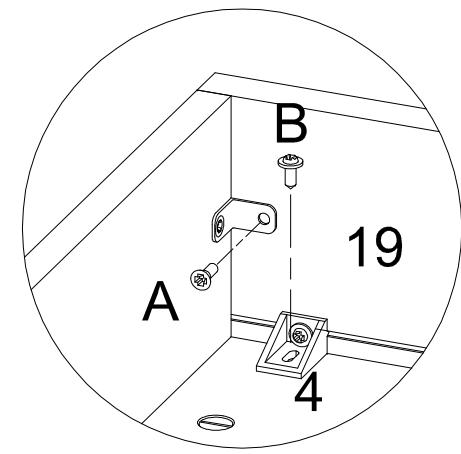
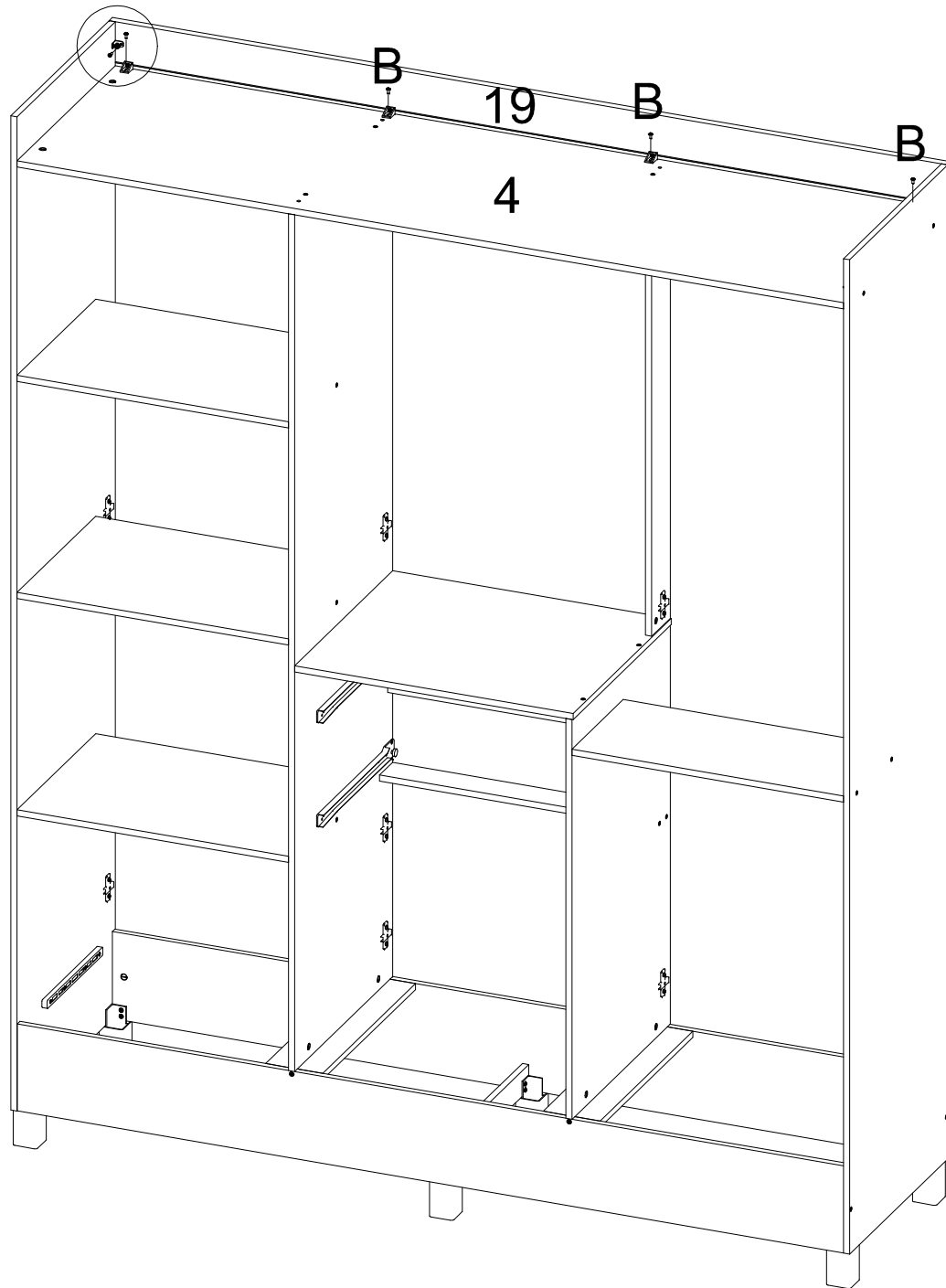

B	X4	A	X2	-	-	-	-	-	-	-	-
---	----	---	----	---	---	---	---	---	---	---	---

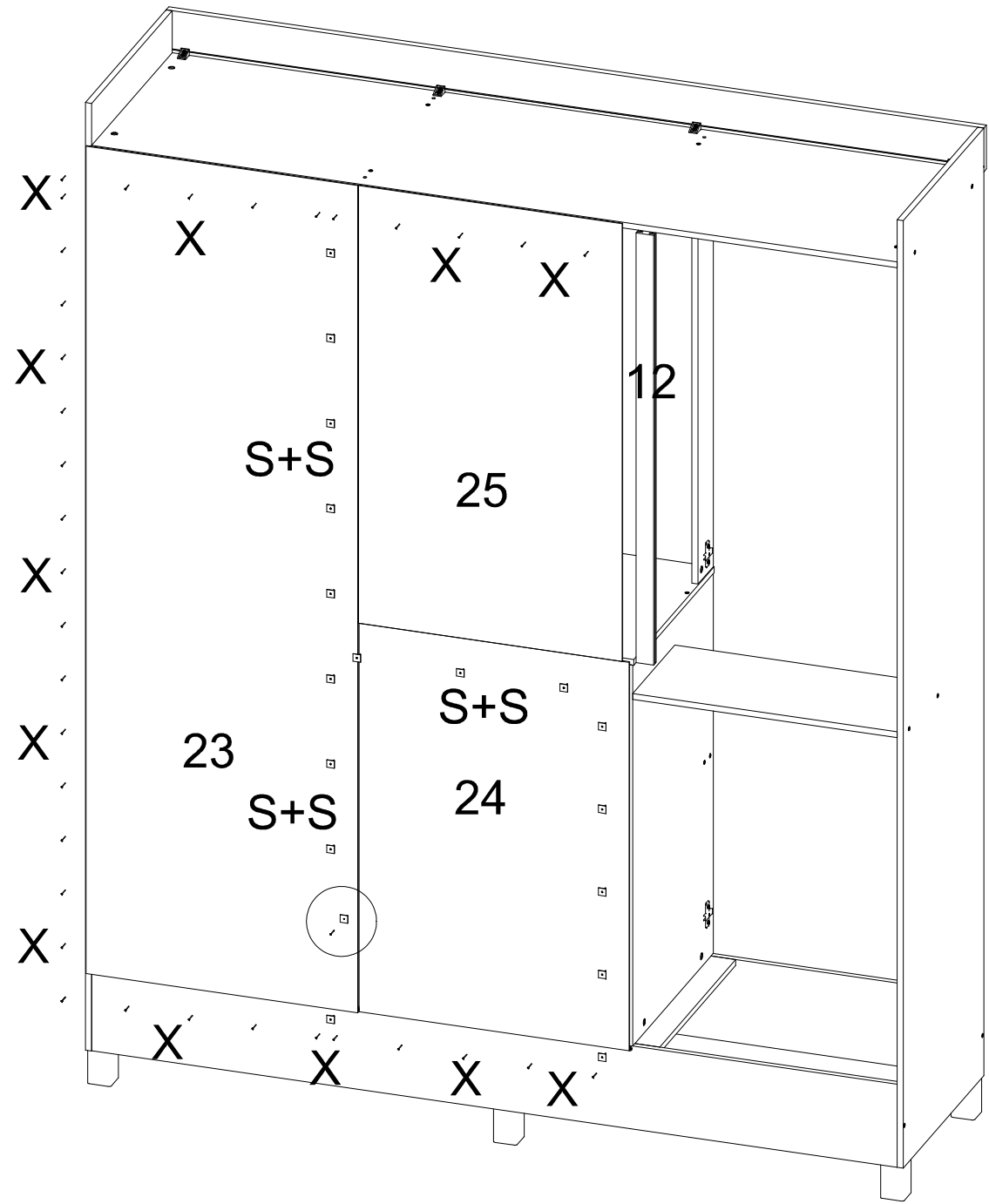

X	S	-	-	-	-	-	-
X52	X20	-	-	-	-	-	-

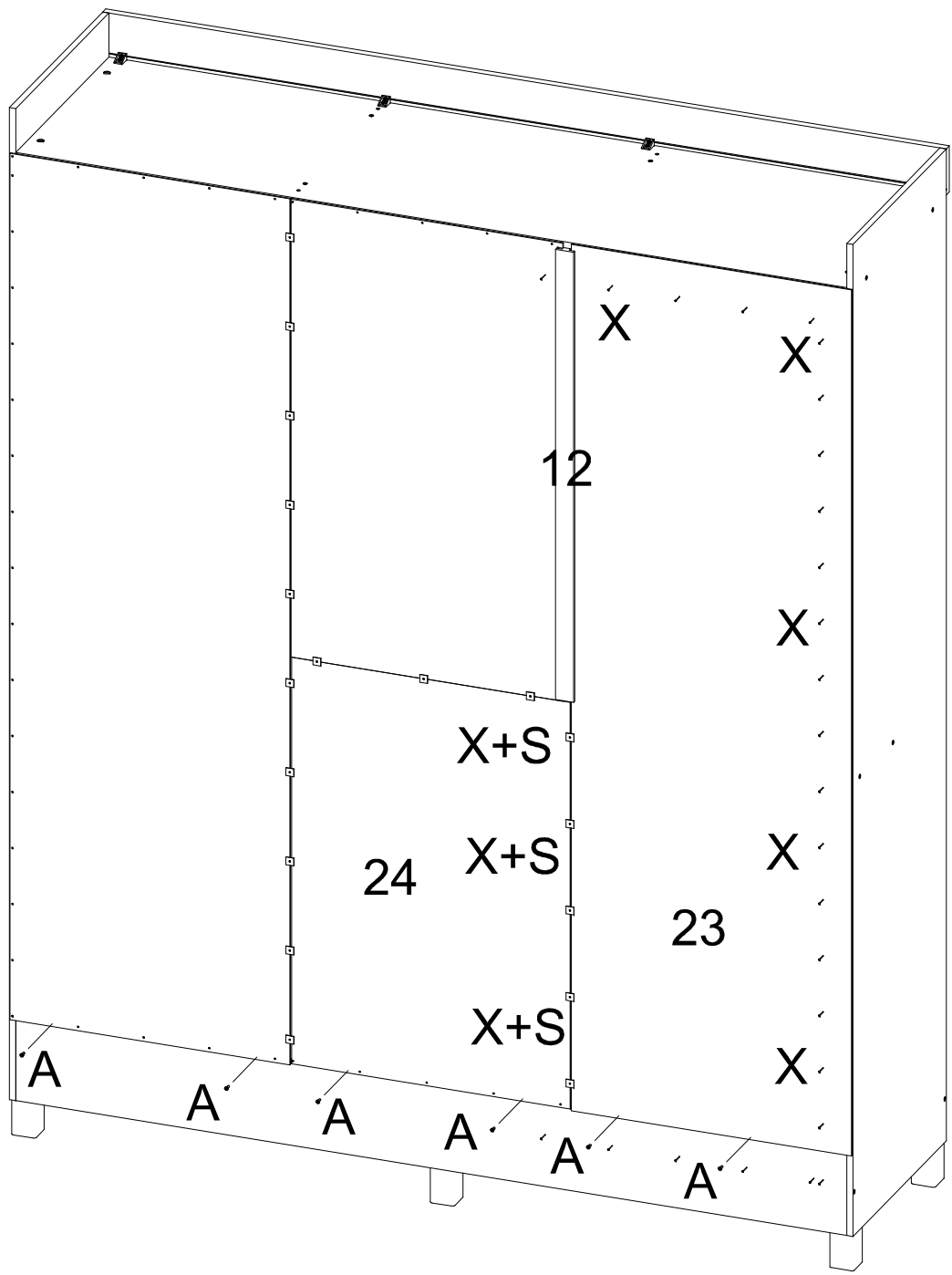

X	S	A	-	-	-	-	-
X40	X5	X6	-	-	-	-	-

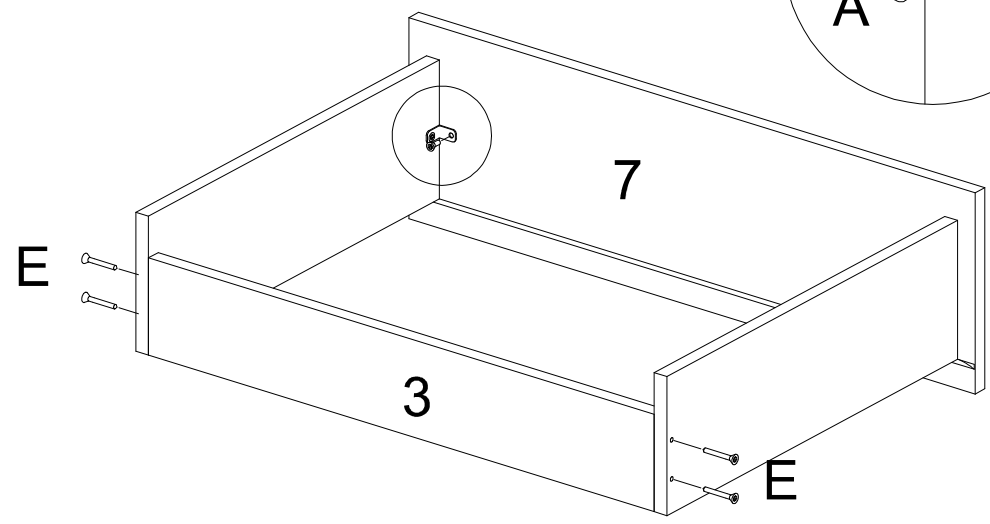
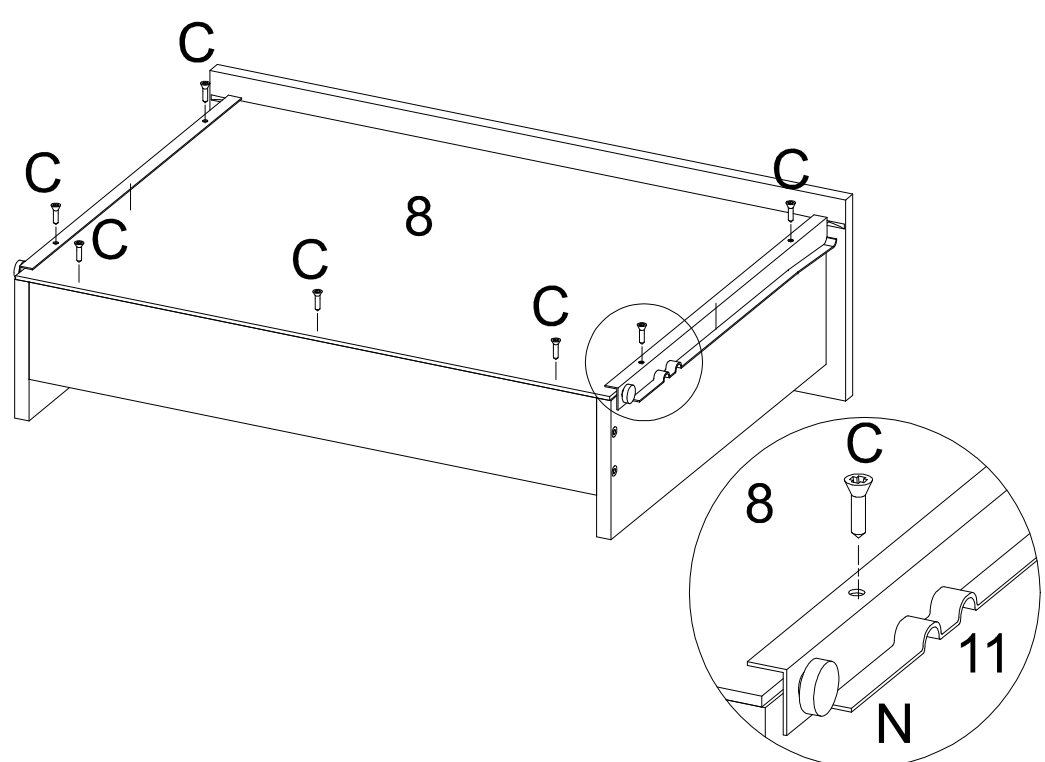
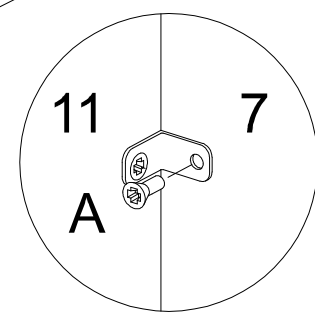
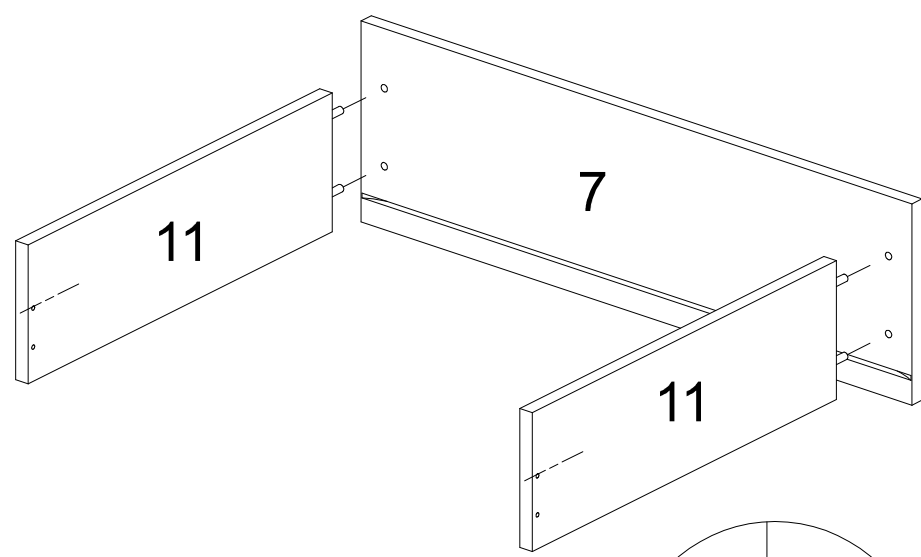
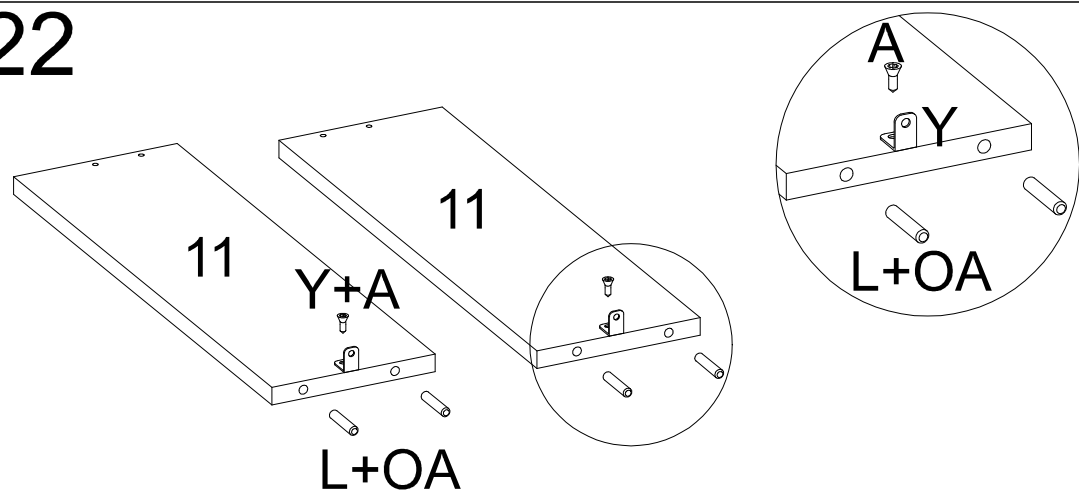

L	Y	A	OA	E	C	N	-
X8	X4	X8	X1	X8	X14	X2	-

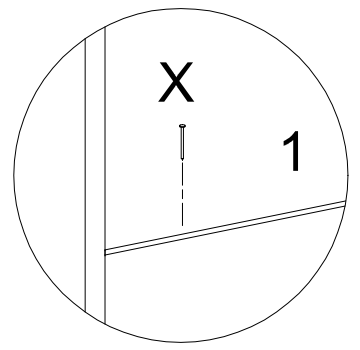
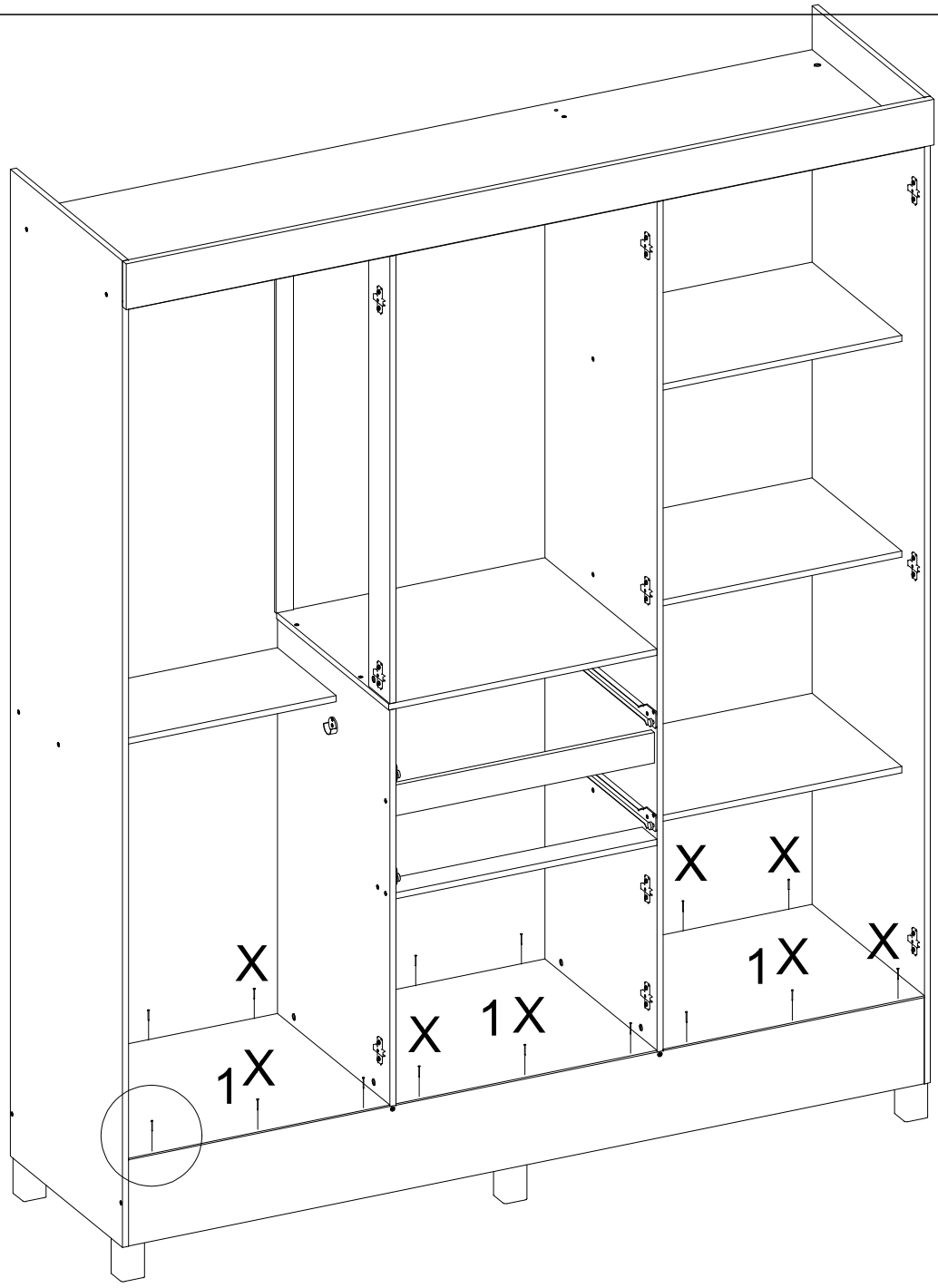

X	-	-	-	-	-	-	-
X18	-	-	-	-	-	-	-

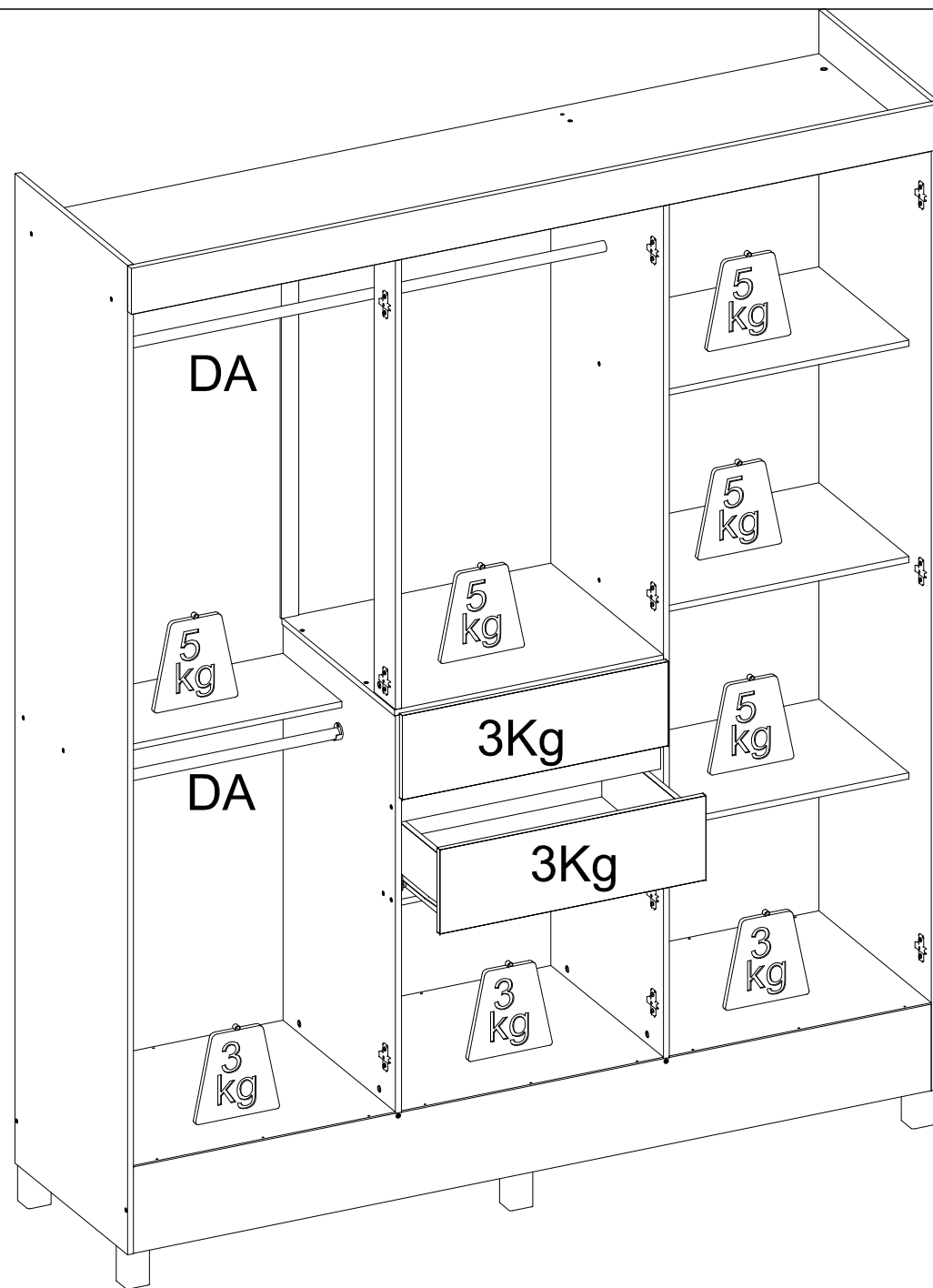

DA X1	DA X1	- -	- -	- -	- -	- -	- -
----------	----------	--------	--------	--------	--------	--------	--------

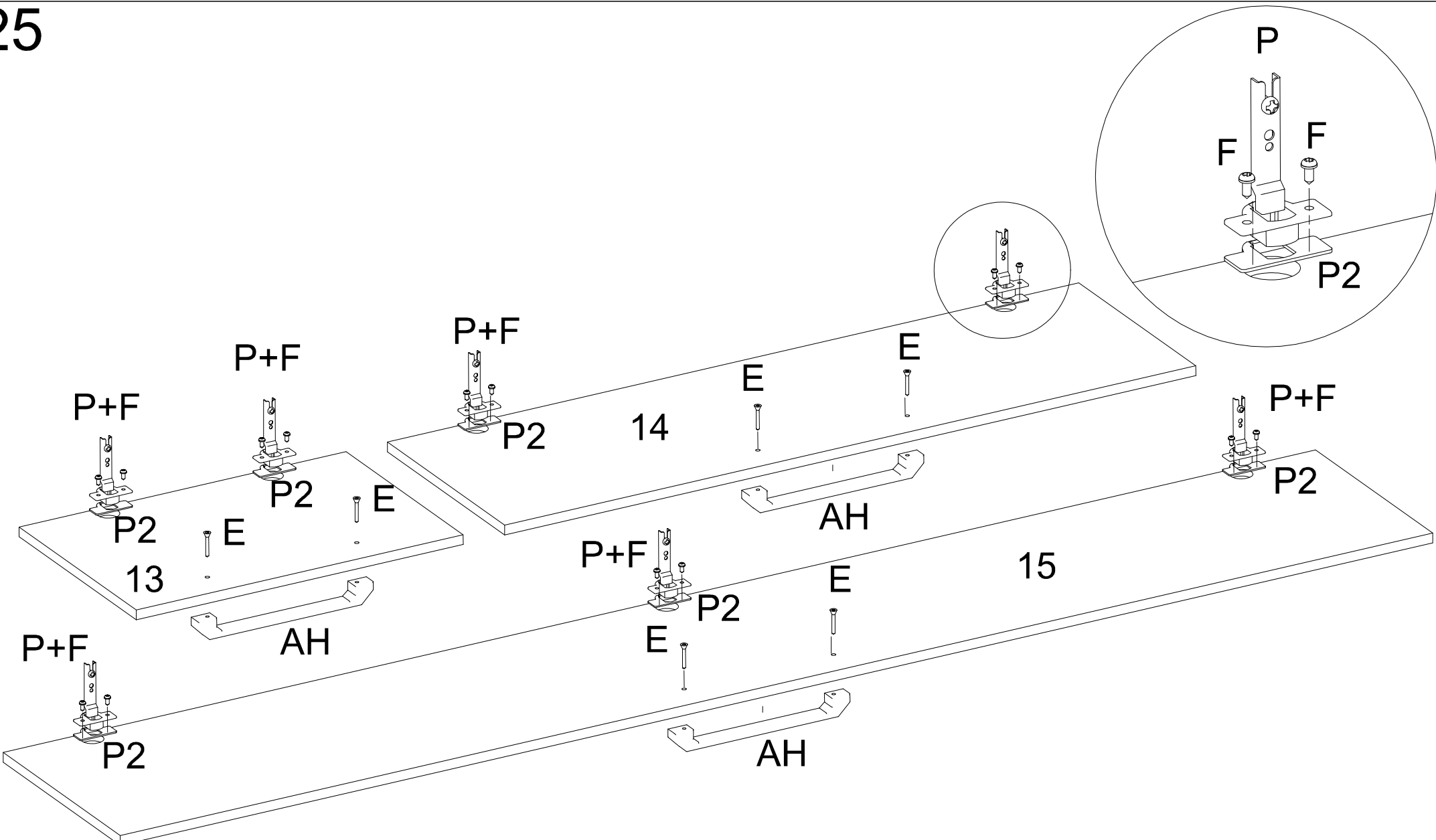

P	P2	F	AH	E	-	-	-
X20	X20	X40	X8	X16	-	-	-

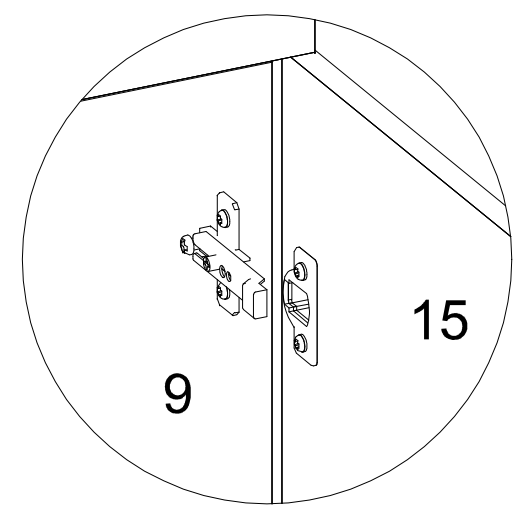
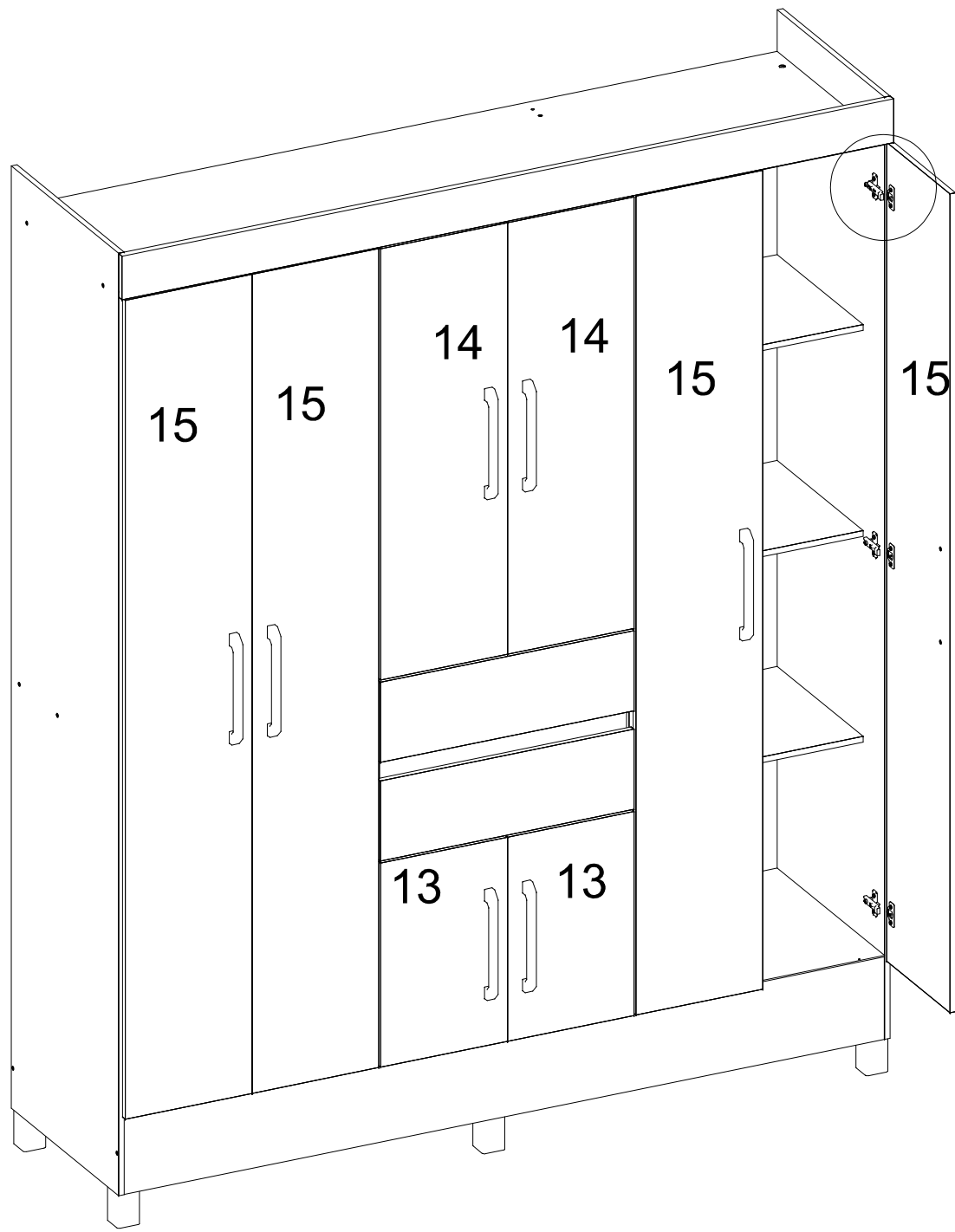

-	-	-	-	-	-	-	-
---	---	---	---	---	---	---	---



-	-	-	-	-	-	-	-
---	---	---	---	---	---	---	---