

## ACESSÓRIOS

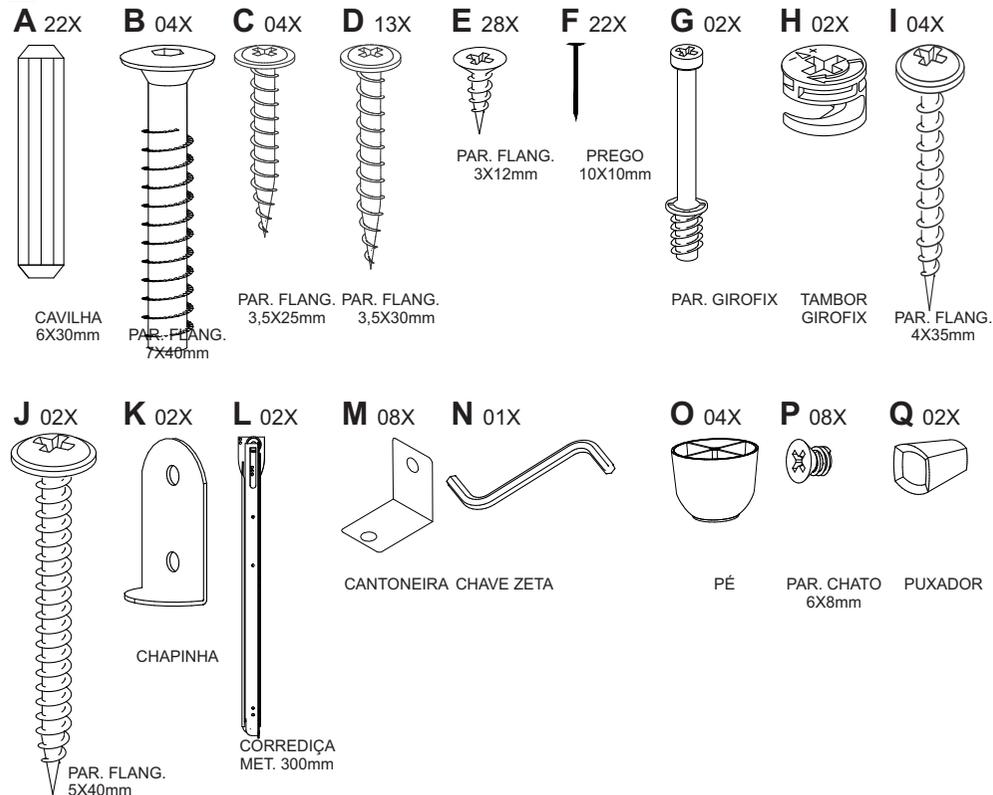

## RELAÇÃO DE PEÇAS

Nº PEÇAS	DESCRIÇÃO	QTD.	MEDIDAS	MATERIAL
01	TAMPO	01	505X335X15	MDP
02	FUNDO APOIO	01	401X77X15	MDP
03	SUORTE MOLDURA	02	850X59X15	MDF
04	LATERAL DIREITA	01	335X305X15	MDP
05	LATERAL ESQUERDA	01	335X305X15	MDP
06	PRATELEIRA	01	440X305X15	MDP
07	BASE	01	505X335X15	MDP
08	FUNDO TRASEIRO	01	460X290X3	HDF
09	MOLDURA ESQUERDA	01	1090X59X15	MDF
10	MOLDURA DIREITA	01	1090X59X15	MDF
11	TRAVA MOLDURA	02	337X30X15	MDP
12	FRENTE GAVETA	02	450X130X15	MDP
13	LATERAL GAVETA	04	300X100X12	MDP
14	FUNDO GAVETA	02	402X305X3	HDF
15	CONTRAFUNDO	02	390X75X12	MDP

## TOUCADOR MAGIC NEW



MANUAL DE MONTAGEM

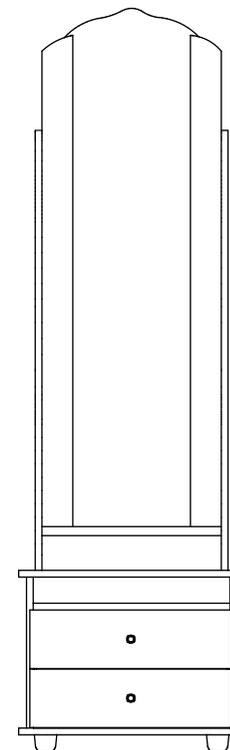

A: 1645mm  
L: 505mm  
P: 335mm

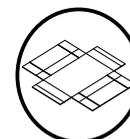

Aconselhamos utilizar a embalagem para dorrar o chão a fim de não danificar o produto



Evitar batidas



Evitar objetos cortantes

### RECOMENDAÇÕES DE USO

- O produto deve ser transportado em sua embalagem para que sejam preservadas suas características;
- A limpeza e manutenção do produto deve ser feita com pano úmido, sem adição de produtos químicos;
- A montagem deve atender aos passos especificados no roteiro de montagem, que se encontra em anexo ao produto;
- Evitar locais úmidos ou com excessiva luz do sol, para maior durabilidade do produto.

### ATENÇÃO

Conferir as medidas dos parafusos e acessórios na escala abaixo antes de utilizá-los

MEDIDAS EM mm



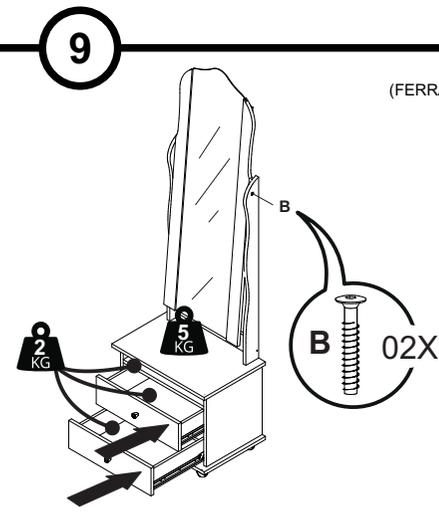
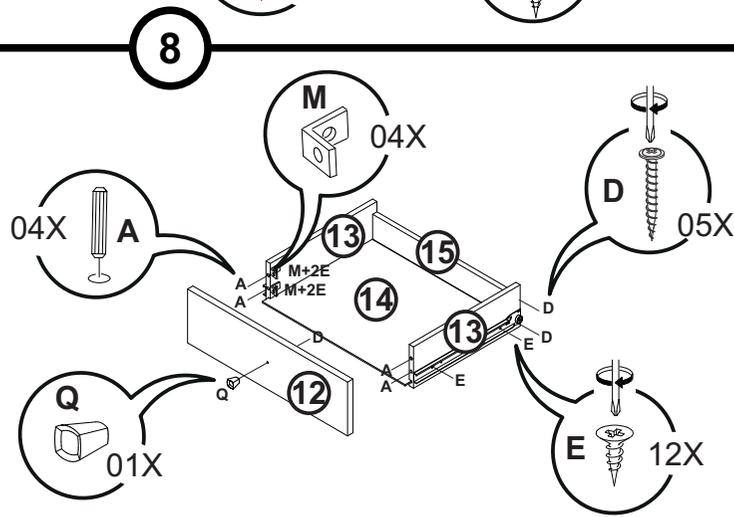
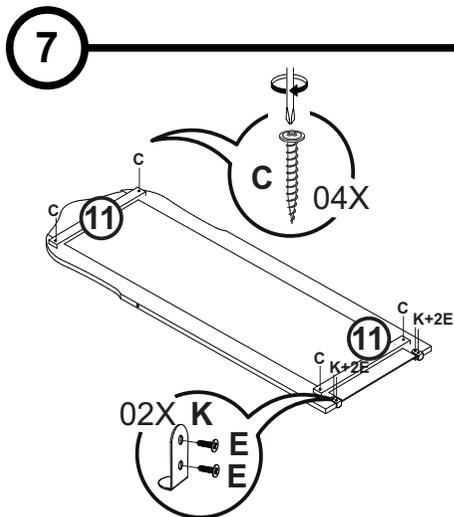
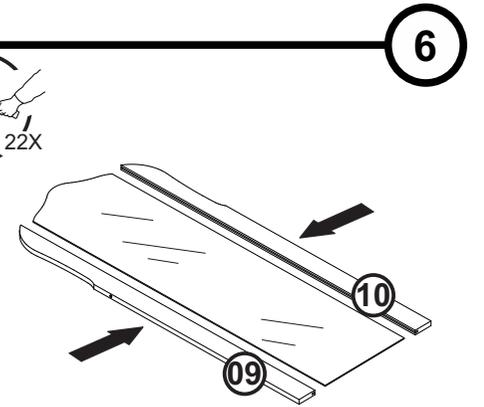
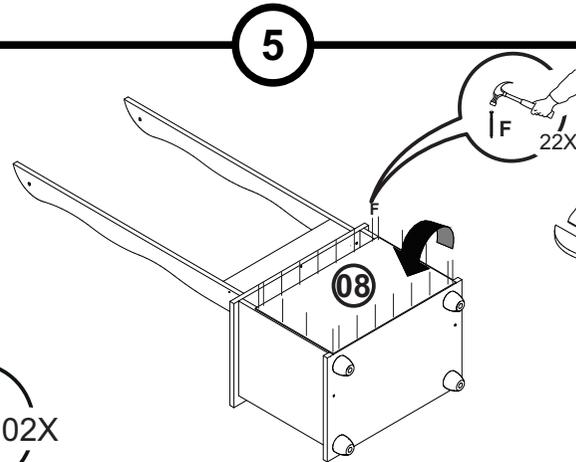
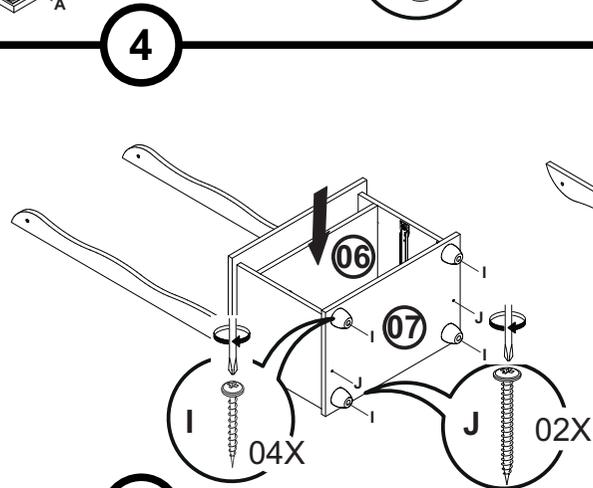
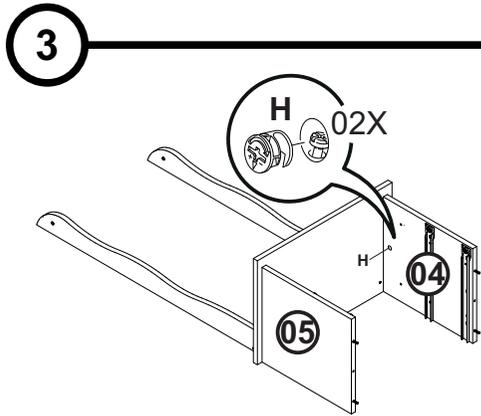
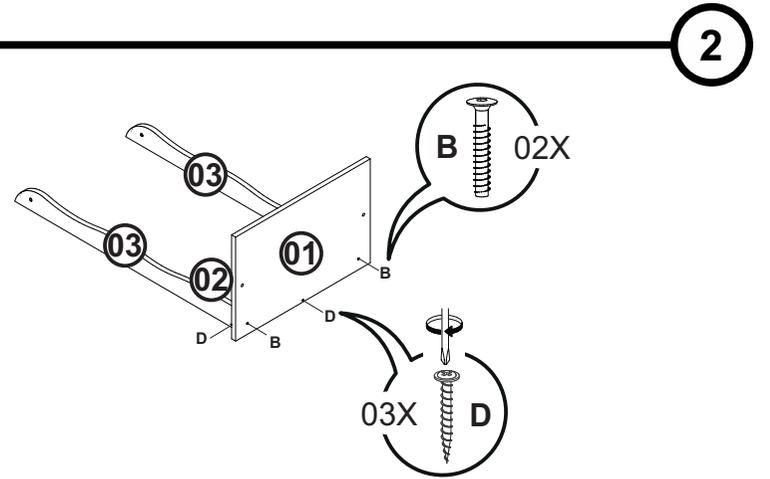
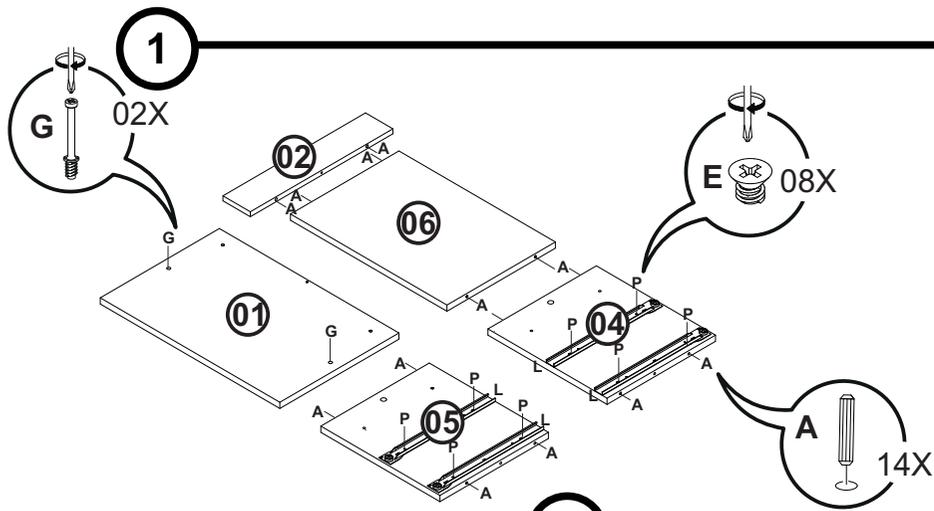

**FERRAMENTAS NECESSÁRIAS**  
(FERRAMENTAS NÃO FORNECIDAS PELA EMPRESA)



CHAVE PHILIPS CHAVE FENDA



PARAFUSADEIRA MARTELO

QUANTIDADE  
NECESSÁRIA DE  
PESSOAS

